

HD Flex™ Fiber Enclosures

specifications

The enclosure shall house, organize, manage and protect fiber optic cable, terminations, splices, connectors and patch cords. Enclosure shall accommodate all HD Flex™ cassettes, fiber adapter panels (FAP), trunk cables, connectors and patch cords. Enclosure shall provide front access with drawers that slide out into two locked positions, regardless of how many enclosures are stacked together. Enclosure trays shall allow for half of the tray to operate independently, an ideal option for redundant networks. Enclosure shall allow cassettes and FAPs to be installed by dropping them into the front of the enclosure tray or sliding them into the rear of the enclosure tray which allows each individual cassette/FAP to be removed with minimal disruption to other cassettes/FAPs. Enclosure shall be constructed of steel material. Enclosures are ordered in either 6-port or 12-port configurations. Enclosure shall be able to be adapted to accept either 6-port cassettes and 12-port cassettes.

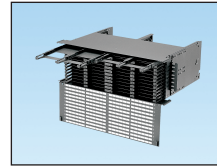
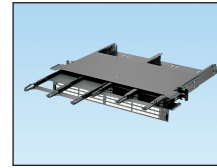

technical information

Mounting:	Integral mounting flange for installation in 19" wide EIA-310 racks
Material:	Steel and plastic

key features and benefits

Modular design accepts up to 12 HD Flex™ Fiber Cassettes or Fiber Adapter Panels per rack unit	Provides higher patch field density in fewer rack units saving valuable rack space
Compatible with all HD Flex™ Fiber Cassettes and Fiber Adapter Panels	Provides versatility and flexibility with a fully modular solution for a variety of pre-terminated installations
Rack/Cabinet Rail Mounting Cable Management Bracket	Provides template for additional mounting of cables, moving cable from back of enclosure to side of enclosure resulting in easy access to connections for improved serviceability
Front and Rear Accessible Enclosure Tray	Allows access to connections from front or rear of rack/cabinet facilitating easy moves, adds and changes without disruption of network connections
Front Drop In and Rear Slide Out Mounting of Cassettes and Fiber Adapter Panels	Allows access to cassettes without fully sliding out cable management plate
Split Enclosure Tray	Allows each half of tray to operate independently providing improved reliability and serviceability of redundant network connections
Multi-positional Enclosure Tray	Allows tray to be locked in two extended positions resulting in improved access when patching and maintaining network connections
Convertible between 6-port and 12-port Cassettes and Fiber Adapter Panels	Accommodates current and future optical connectivity options, duplex and parallel fiber

applications

HD Flex™ Fiber Optic Enclosures provide a system for managing fiber terminations, connections, and patching in all types of applications. The enclosures are a component of the HD Flex™ Fiber Cabling System.

They are ideal for fast, flexible and reliable patch field solutions within main, horizontal and/or equipment distribution areas (MDA, HDA and EDA).

HD Flex™ Fiber Enclosures

1 RU 6-port enclosure:	FLEX1U06
1 RU 12-port enclosure:	FLEX1U12
2 RU 6-port enclosure:	FLEX2U06
2 RU 12-port enclosure:	FLEX2U12
4 RU 6-port enclosure:	FLEX4U06
4 RU 12-port enclosure:	FLEX4U12

HD Flex™ Trunk Transition Clips

12-fiber capacity:	FLEX-CLIP12
18-fiber capacity:	FLEX-CLIP18

HD Flex™ Trunk Cable Managers

Universal Trunk Managers	
12-fiber transition capacity:	FLEX-CM12S
Universal Trunk Managers	
12-fiber transition capacity:	FLEX-CM12S
18-fiber transition capacity:	FLEX-CM18S
PatchRunner™ Trunk Managers	
12-fiber transition capacity:	FLEX-CM12C
18-fiber transition capacity:	FLEX-CM18C

HD Flex™ Trunk Slack Plates

1 RU:	FLEX-PLATE1U
4 RU:	FLEX-PLATE4U

HD Flex™ Fiber Enclosures

fiber capacity

Description	Enclosure		
	1 RU	2 RU	4 RU
12F MPO to 6 Duplex LC	144	288	576
24F MPO to 12 Duplex LC	144	288	576
4-to-1 Breakout	96	192	384
12-to-3 Breakout	144	288	576
6 Port 12F MPO FAP	864	1728	3456
6 Port 24F MPO FAP	1728	3456	6912

For dimensions, please go to www.panduit.com/hdflex for the part drawings.

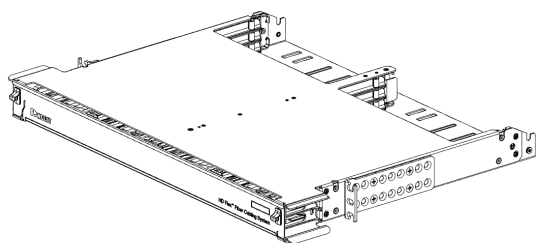

FLEX1U06

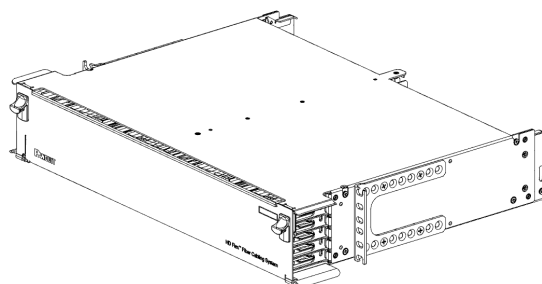

FLEX2U06

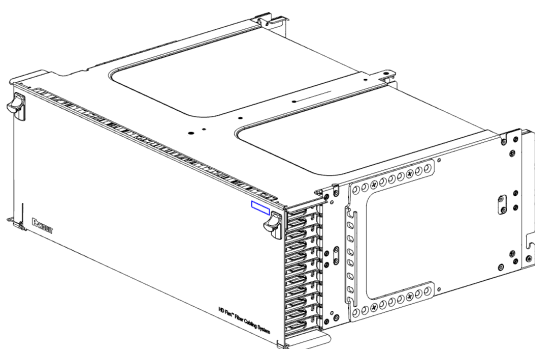

FLEX4U06

WORLDWIDE SUBSIDIARIES AND SALES OFFICES

PANDUIT CANADA
Markham, Ontario
cs-cdn@panduit.com
Phone: 800.777.3300

PANDUIT EUROPE LTD.
London, UK
cs-emea@panduit.com
Phone: 44.20.8601.7200

PANDUIT SINGAPORE PTE. LTD.
Republic of Singapore
cs-ap@panduit.com
Phone: 65.6305.7575

PANDUIT JAPAN
Tokyo, Japan
cs-japan@panduit.com
Phone: 81.3.6863.6000

PANDUIT LATIN AMERICA
Guadalajara, Mexico
cs-la@panduit.com
Phone: 52.33.3777.6000

PANDUIT AUSTRALIA PTY. LTD.
Victoria, Australia
cs-aus@panduit.com
Phone: 61.3.9794.9020

For a copy of Panduit product warranties, log on to www.panduit.com/warranty

For more information

Visit us at www.panduit.com

Contact Customer Service by email: cs@panduit.com
or by phone: 800.777.3300

PANDUIT®

© 2017 Panduit Corp.
ALL RIGHTS RESERVED.
FBSP92--WW-ENG
1/2017