



# A Resilient Converged Plantwide Ethernet Architecture

## White Paper

August 2020

### Rockwell Automation and Cisco Four Key Initiatives:

- **Common Technology View:**  
A single scalable architecture, using open EtherNet/IP™ standard networking technologies, is paramount to enable the Industrial Internet of Things for achieving the flexibility, visibility, and efficiency required in a competitive manufacturing environment.
- **Converged Plantwide Ethernet Architectures:**  
Collection of tested and validated architectures developed by subject matter authorities at Cisco, Panduit, and Rockwell Automation. The content of CPwE is relevant to both Operational Technology (OT) and Information Technology (IT) disciplines and consists of documented architectures, best practices, guidance, and configuration settings to help manufacturers with design and deployment of a scalable, reliable, safe, secure, and future-ready plant-wide industrial network infrastructure.
- **Joint Product Collaboration:**  
Stratix® 5950 industrial firewall, FactoryTalk® Network Manager™ software, Stratix 5700, Stratix 5400, Stratix 5410, and Stratix 5800 Industrial Ethernet Switches, incorporating the best of Cisco and the best of Rockwell Automation.
- **People and Process Optimization:**  
Education and services to facilitate Operational Technology (OT) and Information Technology (IT) convergence, which can assist with successful architecture deployment, and helps to enable efficient operations that allow critical resources to focus on increasing innovation and productivity.

Document Reference Number: ENET-WP039E-EN-P

# A Resilient Converged Plantwide Ethernet Architecture

The prevailing trend in Industrial Automation and Control System (IACS) networking is the convergence of technology, specifically IACS operational technology (OT) with information technology (IT). Converged Plantwide Ethernet (CPwE) helps to enable IACS network and security technology convergence, including OT-IT persona convergence, by using standard Ethernet, Internet Protocol (IP), network services, security services, and EtherNet/IP. A reliable and secure converged plant-wide or site-wide IACS architecture helps to enable the Industrial Internet of Things (IIoT).

Business practices, corporate standards, policies, industry standards, and tolerance to risk are key factors in determining the degree of resiliency and application availability required within an IACS plant-wide or site-wide architecture, for example, non-resilient LAN, resilient LAN, or redundant LANs. A resilient network architecture within an IACS application plays a pivotal role in helping to minimize the risk of IACS application shutdowns while helping to maximize overall plant/site uptime.

A holistic resilient plant-wide or site-wide network architecture is composed of multiple technologies (logical and physical) deployed at different levels within the plant/site. When selecting a resiliency technology, various plant/site application factors should be evaluated, including the physical layout of IACS devices (geographic dispersion), recovery time performance, uplink media type, tolerance to data latency and jitter, and future-ready requirements:

- Robust physical infrastructure
- Topologies and protocols
- Switching and routing
- Wireless LAN Controllers (WLC)
- Firewalls
- Network and device management

*Deploying a Resilient Converged Plantwide Ethernet Architecture Design and Implementation Guide (DIG)* outlines several use cases for designing and deploying resilient plant-wide or site-wide LAN architectures for IACS applications. CPwE Resiliency was architected, tested and validated by Cisco Systems, Panduit, and Rockwell Automation.

## CPwE Overview

CPwE is the underlying architecture that provides standard network and security services for control and information disciplines, devices, and equipment found in modern IACS applications. The CPwE architectures (Figure 1) were architected, tested, and validated to provide design and implementation guidance, test results, and documented configuration settings. This can help to achieve the real-time communication, reliability, scalability, security, and resiliency requirements of modern IACS applications. The content and key tenets of CPwE are relevant to both OT and IT disciplines. CPwE key tenets include:

- Smart IIoT devices—Controllers, I/O, drives, instrumentation, actuators, analytics, and a single IIoT network technology (EtherNet/IP), facilitating both technology coexistence and IACS device interoperability, which helps to enable the choice of best-in-class IACS devices
- Zoning (segmentation)—Smaller connected LANs, functional areas, and security groups
- Managed infrastructure—Managed Allen-Bradley® Stratix industrial Ethernet switches (IES), Cisco Catalyst® distribution/core switches, FactoryTalk Network Manager software, and Stratix industrial firewalls
- Resiliency—Robust physical layer and resilient or redundant topologies with resiliency protocols
- Time-critical data—Data prioritization and time synchronization via CIP Sync™ and IEEE-1588 Precision Time Protocol (PTP)
- Wireless—Unified wireless LAN (WLAN) to enable mobility for personnel and equipment
- Holistic defense-in-depth security—Multiple layers of diverse technologies for threat detection and prevention, implemented by different persona (for example, OT and IT) and applied at different levels of the plant-wide or site-wide IACS architecture
- Convergence-ready—Seamless plant-wide or site-wide integration by trusted partner applications.

Figure 1 CPwE Architectures

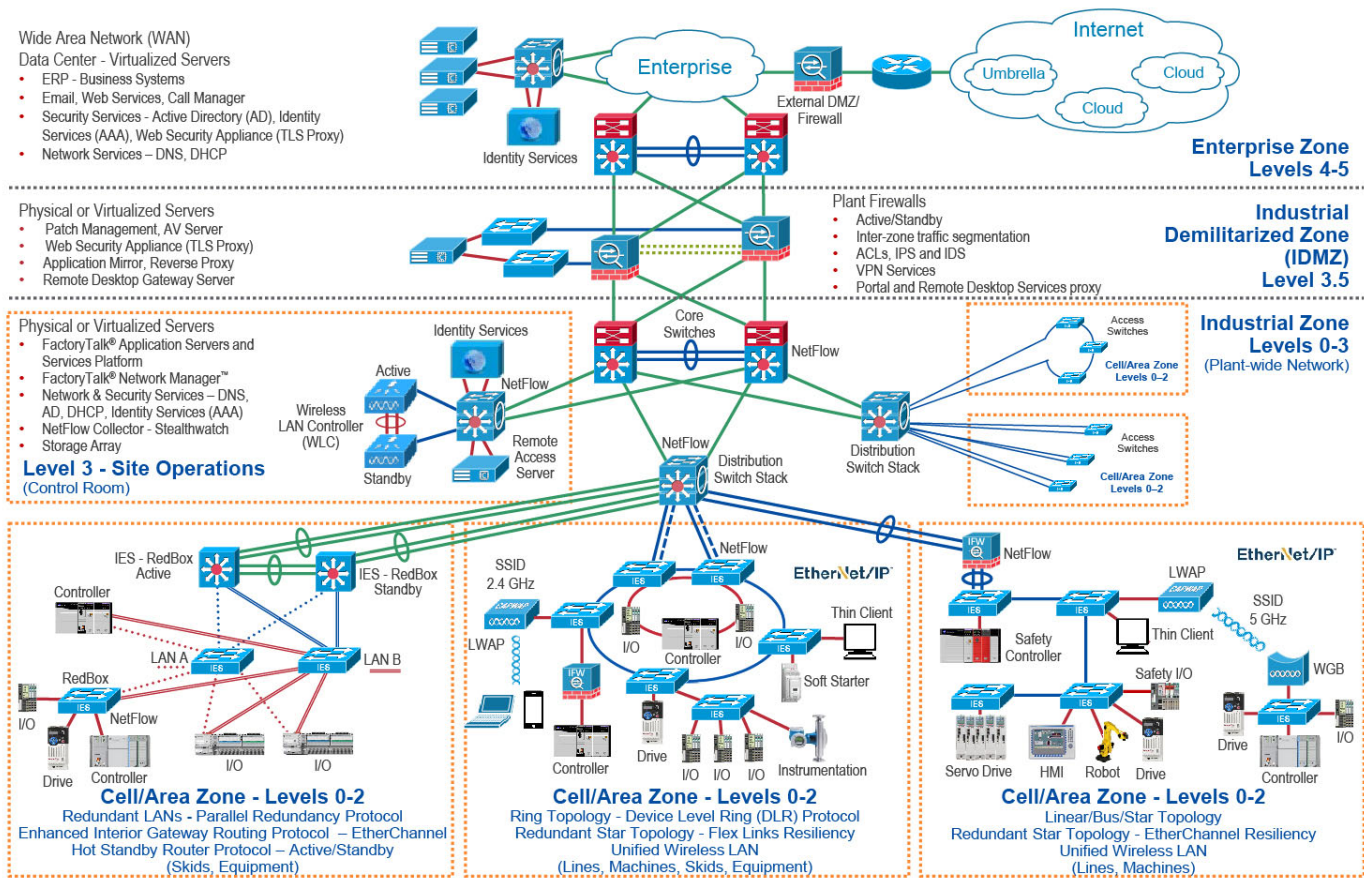

**Note**

This release of the CPwE architecture focuses on EtherNet/IP which uses the ODVA, Inc. Common Industrial Protocol (CIP™) and is ready for the Industrial Internet of Things (IIoT). For more information on EtherNet/IP, CIP Sync, and DLR, see [odva.org](http://www.odva.org) at the following URL:

- <http://www.odva.org/Technology-Standards/EtherNet-IP/Overview>

# CPwE Resilient IACS Architectures Overview

An IACS is deployed in a wide variety of industries such as automotive, pharmaceuticals, consumer packaged goods, pulp and paper, oil and gas, mining, and energy. IACS applications are composed of multiple control and information disciplines such as continuous process, batch, discrete, and hybrid combinations. One of the challenges facing industrial operations is the industrial hardening of standard Ethernet and IP-converged IACS networking technologies to take advantage of the business benefits associated with IIoT. A resilient LAN architecture can help to increase the overall equipment effectiveness (OEE) of the IACS by helping to reduce the impact of a failure and speed recovery from an outage, which lowers Mean-Time-to-Repair (MTTR).

Protecting availability for IACS assets requires a scalable defense-in-depth approach where different solutions are needed to address various network resiliency requirements for OEM, plant-wide or site-wide architectures. This section summarizes the Cisco, Panduit, and Rockwell Automation CPwE validated designs that address different aspects of availability for IIoT IACS applications.

- *Deploying Device Level Ring within a Converged Plantwide Ethernet Architecture Design and Implementation Guide* outlines several use cases for designing and deploying DLR technology with IACS device-level, switch-level, and mixed device/switch-level single and multiple ring topologies across OEM and plant-wide or site-wide resilient LAN IACS applications.
  - Rockwell Automation site:  
[https://literature.rockwellautomation.com/idc/groups/literature/documents/td/enet-td015\\_-en-p.pdf](https://literature.rockwellautomation.com/idc/groups/literature/documents/td/enet-td015_-en-p.pdf)
  - Cisco site:  
<https://www.cisco.com/c/en/us/td/docs/solutions/Verticals/CPwE/5-1/DLR/DIG/CPwE-5-1-DLR-DIG.html>
- *Deploying Parallel Redundancy Protocol within a Converged Plantwide Ethernet Architecture Design and Implementation Guide* outlines several use cases for designing and deploying Parallel Redundancy Protocol (PRP) technology with redundant LANs across plant-wide or site-wide IACS applications.
  - Rockwell Automation site:  
[https://literature.rockwellautomation.com/idc/groups/literature/documents/td/enet-td021\\_-en-p.pdf](https://literature.rockwellautomation.com/idc/groups/literature/documents/td/enet-td021_-en-p.pdf)
  - Cisco site:  
<https://www.cisco.com/c/en/us/td/docs/solutions/Verticals/CPwE/5-1/PRP/DIG/CPwE-5-1-PRP-DIG.html>
- *Deploying a Fiber Optic Physical Infrastructure within a Converged Plantwide Ethernet Architecture Application Guide* helps designers and installers select and deploy fiber optic media in plant/site environments. It details fiber optic network infrastructure solutions that provide high-performance connectivity options that help increase the integrity and availability of a CPwE architecture at each level of the OEM, plant-wide or site-wide network.
  - Rockwell Automation site:  
[https://literature.rockwellautomation.com/idc/groups/literature/documents/td/enet-td003\\_-en-p.pdf](https://literature.rockwellautomation.com/idc/groups/literature/documents/td/enet-td003_-en-p.pdf)
  - Cisco site:  
<https://www.cisco.com/c/en/us/td/docs/solutions/Verticals/CPwE/5-1/FOI/CPwE-5-1-FOI-AG.html>
- *Physical Infrastructure for the Converged Plantwide Ethernet Architecture Application Guide* which helps customers address the physical deployment associated with converged plant-wide or site-wide EtherNet/IP architectures. As a result, users can achieve resilient, scalable EtherNet/IP networks that can support proven and flexible CPwE logical architectures designed to help optimize OEM, plant-wide or site-wide IACS network performance.
  - Rockwell Automation site:  
[https://literature.rockwellautomation.com/idc/groups/literature/documents/td/enet-td020\\_-en-p.pdf](https://literature.rockwellautomation.com/idc/groups/literature/documents/td/enet-td020_-en-p.pdf)
  - Cisco site:  
[https://www.cisco.com/c/en/us/td/docs/solutions/Verticals/CPwE/5-1/Phy\\_Arch/CPwE\\_PhysArch\\_AppGuide.html](https://www.cisco.com/c/en/us/td/docs/solutions/Verticals/CPwE/5-1/Phy_Arch/CPwE_PhysArch_AppGuide.html)
- *Deploying A Resilient Converged Plantwide Ethernet Architecture Design and Implementation Guide* outlines several use cases for designing and deploying resilient plant-wide or site-wide architectures for IACS applications, utilizing a robust physical layer and resilient LAN topologies with resiliency protocols.
  - Industrial Zone:
    - Core Switching

- Aggregation/Distribution Switching
- Robust Physical Infrastructure
- Cell/Area Zone:
  - Redundant Path Topology with Resiliency Protocol
  - Industrial Ethernet Switching
  - Robust Physical Infrastructure
- Rockwell Automation site:
  - [https://literature.rockwellautomation.com/idc/groups/literature/documents/td/enet-td010\\_-en-p.pdf](https://literature.rockwellautomation.com/idc/groups/literature/documents/td/enet-td010_-en-p.pdf)
- Cisco site:
  - [https://www.cisco.com/c/en/us/td/docs/solutions/Verticals/CPwE/4-0/Resiliency/DIG/CPwE\\_resil\\_CVD.html](https://www.cisco.com/c/en/us/td/docs/solutions/Verticals/CPwE/4-0/Resiliency/DIG/CPwE_resil_CVD.html)

## CPwE Resiliency Solution Use Cases

The CPwE Resiliency architecture supports scalability which includes the degree of resiliency applied to a plant-wide or site-wide architecture. Scalable resiliency comes in many forms; that is, technology choices in topology and distribution switch. For the *Deploying a Resilient Converged Plantwide Ethernet Architecture DIG*, the following represents a portion of the use cases that were architected, tested, validated and documented by Cisco Systems, Panduit, and Rockwell Automation.

### Allen-Bradley Stratix and Cisco Industrial Ethernet Switches (IES)

Refer to [Figure 2](#).

- Form factor:
  - DIN rail / panel mount
  - 19" rack mount - 1 RU (rack unit)
- Hot Standby Routing Protocol (HSRP) first hop redundancy protocol
- Redundant star switch-level topology:
  - Flex Links resiliency protocol
  - MSTP resiliency protocol
- Ring switch-level topology:
  - Resilient Ethernet Protocol (REP)
  - Device Level Ring Protocol (see CPwE DLR)
  - Multiple Spanning Tree Protocol (MSTP) resiliency protocol
  - Single and dual media ring:
    - EtherChannel for dual media ring only



Figure 2 IES Aggregation/Distribution Switch

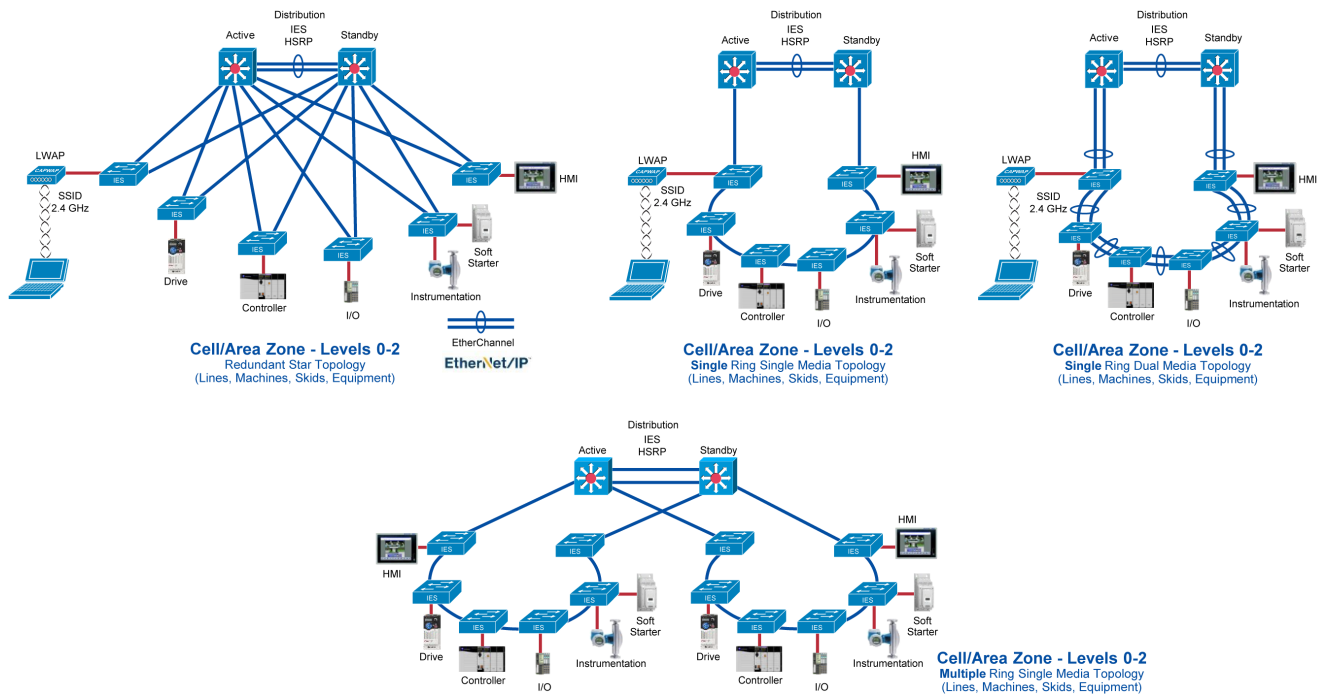

## Catalyst 9500 Aggregation/Distribution Switches

Refer to [Figure 3](#).

- Cisco Catalyst 9000 platform StackWise Virtual technology allows the clustering of two physical switches together into a single logical entity. The two switches operate as one; they share the same configuration and forwarding state. This technology allows for enhancements in all areas of network design, including high availability, scalability, management, and maintenance. StackWise Virtual also incorporates many other Cisco innovations, such as Stateful Switch Over (SSO), Non-Stop Forwarding (NSF), and Multi-chassis EtherChannel (MEC).
- Hot Standby Routing Protocol (HSRP) first hop redundancy protocol
- Redundant star switch-level topology:
  - Multi-chassis EtherChannel (MEC) port aggregation
  - Flex Links resiliency protocol
  - MSTP resiliency protocol
- Ring switch-level topology:
  - REP
  - MSTP resiliency protocol
  - Single and dual media ring

## Catalyst 4500-X Aggregation/Distribution Switches

Refer to [Figure 3](#).

- Virtual Switching System (VSS) virtualization technology that combines two physical switch chassis into one virtual switch, with Stateful Switch Over (SSO) and Non-stop forwarding (NSF)
- Hot Standby Routing Protocol (HSRP) first hop redundancy protocol
- Redundant star switch-level topology:
  - Multi-chassis EtherChannel (MEC) port aggregation
  - Flex Links resiliency protocol
  - MSTP resiliency protocol
- Ring switch-level topology:
  - REP
  - MSTP resiliency protocol
  - Single and dual media ring

**Note**

---

Cisco, Panduit, and Rockwell Automation recommend migrating from Catalyst 4500-X to Catalyst 9500 series as the aggregation/distribution switch platform.

---



Figure 3 Catalyst 9500 or Catalyst 4500-X Aggregation/Distribution Switch

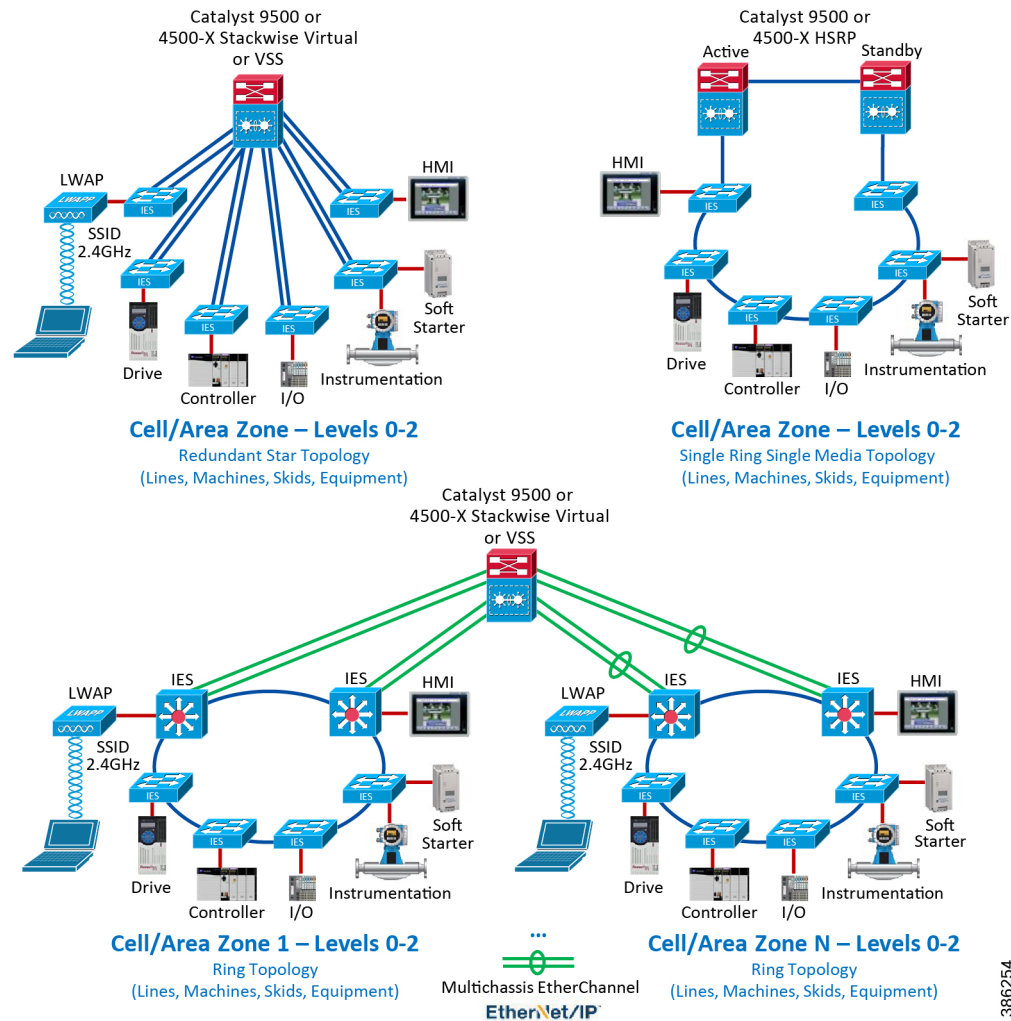

## Catalyst 9300 StackWise-480 Aggregation/Distribution Switch

Refer to [Figure 4](#).

- Switch stack, which is a set of up to eight stacking-capable switches, connected through their StackWise-480 ports, and united to form a logical unit
- Redundant star switch-level topology:
  - EtherChannel port aggregation
  - Flex Links resiliency protocol
  - MSTP resiliency protocol
- Ring switch-level topology:
  - REP
  - MSTP resiliency protocol

- Single and dual media ring

## Catalyst 3850 StackWise-480 Aggregation/Distribution Switch

Refer to [Figure 4](#).

- Switch stack, which is a set of up to nine stacking-capable switches, connected through their StackWise-480 ports, and united to form a logical unit
- Redundant star switch-level topology:
  - EtherChannel port aggregation
  - Flex Links resiliency protocol
  - MSTP resiliency protocol
- Ring switch-level topology:
  - REP
  - MSTP resiliency protocol
  - Single and dual media ring

**Note**

---

Cisco, Panduit, and Rockwell Automation recommend migrating from Catalyst 3850 to Catalyst 9300 series as the aggregation/distribution switch platform.

---

Figure 4 Catalyst 9300 or Catalyst 3850 StackWise-480

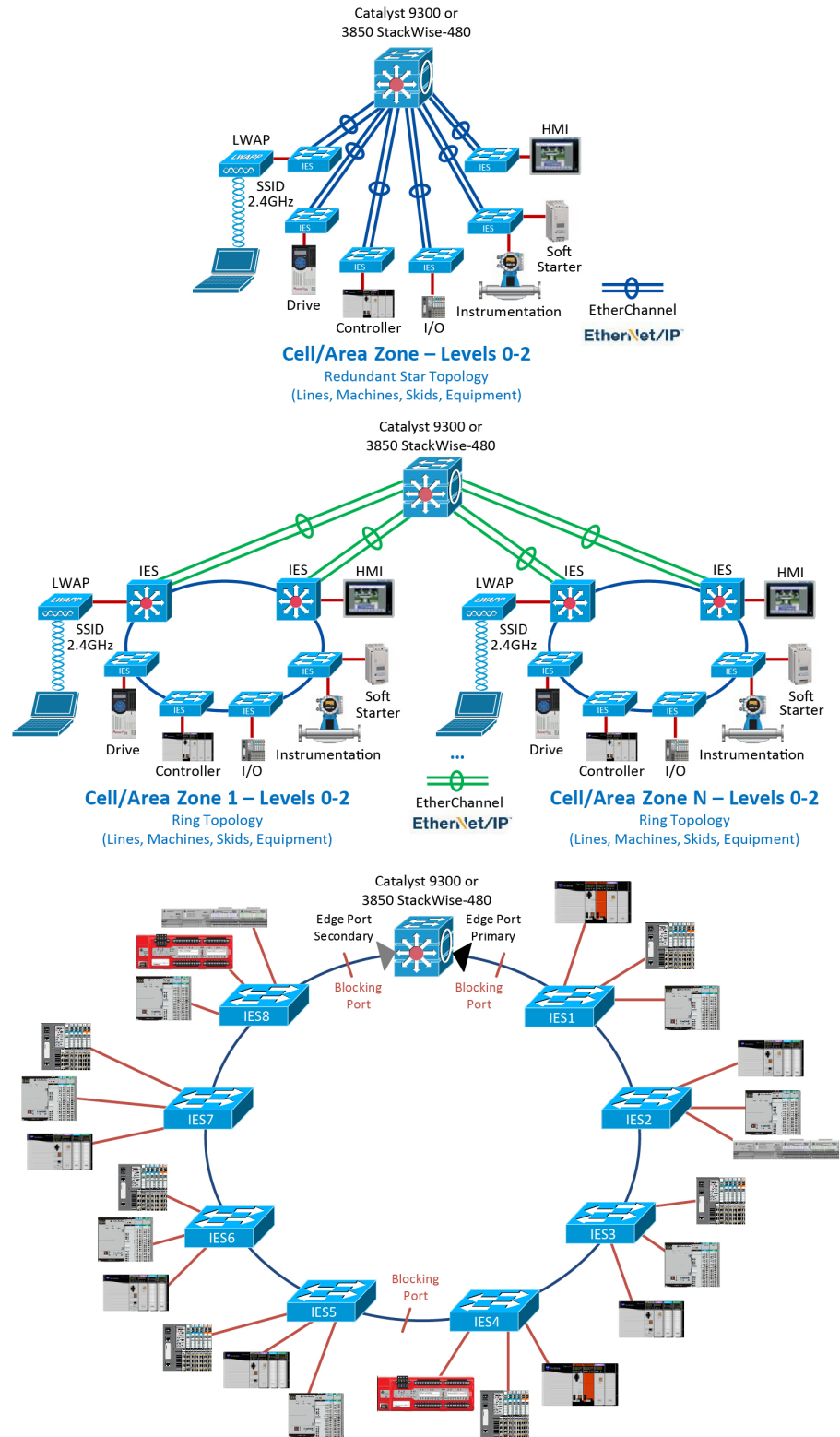

386255

## Core Switches

Large scale architectures typically use modular chassis-based core switches, such as Cisco Catalyst 9600 and 6800 platforms. In addition to having redundant hardware components, core switches are configured as resilient pairs utilizing StackWise Virtual or VSS technology.

Refer to [Figure 5](#).

Figure 5 Core Switches—Traditional versus VSS Design

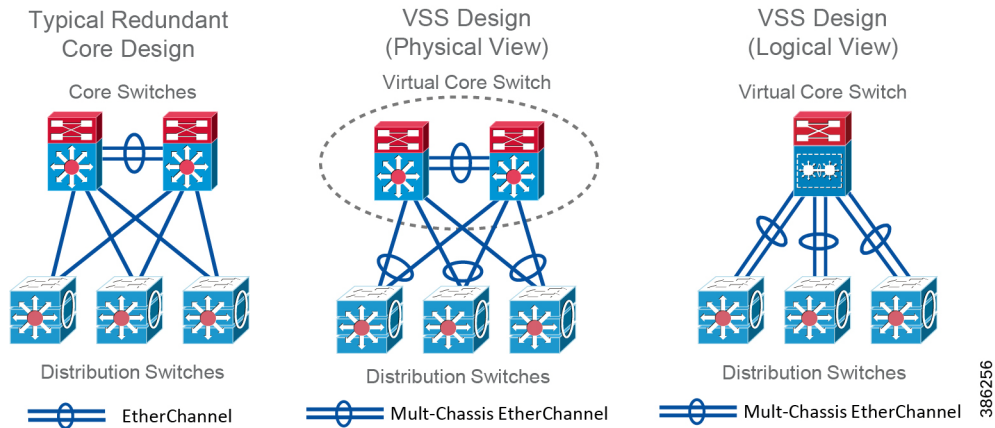

Medium and small-scale architectures can use fixed-size switch platforms as a core, such as Cisco Catalyst 9500 with StackWise Virtual technology, or use a collapsed core/distribution model.

## Robust Physical Infrastructure

Successful deployment of CPwE logical architectures depends on a robust physical infrastructure network design that addresses environmental and performance challenges with best practices from Operational Technology (OT) and Information Technology (IT). For the *Deploying a Resilient Converged Plantwide Ethernet Architecture DIG*, Cisco, Panduit and Rockwell Automation have collaborated to reference Panduit's building block approach for physical infrastructure deployment. This approach is reflected in *Physical Infrastructure for the Converged Plantwide Ethernet Architecture Application Guide*, which helps customers address the physical deployment associated with converged plant-wide or site-wide EtherNet/IP. As a result, users can achieve resilient, scalable networks that can support proven and flexible CPwE logical architectures designed to help optimize plant-wide or site-wide IACS network performance.

Refer to [Figure 6](#).

For *Physical Infrastructure for the Converged Plantwide Ethernet Architecture Application Guide*, the following use cases were documented by Panduit:

- Robust physical infrastructure design considerations and best practices
- Control Panel:
  - Electromagnetic interference (EMI) noise mitigation through bonding, shielding and grounding
  - Industrial Ethernet Switch (IES) deployment within the Cell/Area Zone
- Physical Network Zone System:
  - IES and Access Point (AP) deployment within the Cell/Area Zone
- Cable distribution across the Industrial Zone

- Industrial Distribution Frame (IDF):
  - Industrial aggregation/distribution switch deployment within the Industrial Zone
- Industrial Data Center (IDC):
  - Physical design and deployment of the Level 3 Site Operations

Figure 6 Panduit Robust Physical Infrastructure for the CPwE Architecture

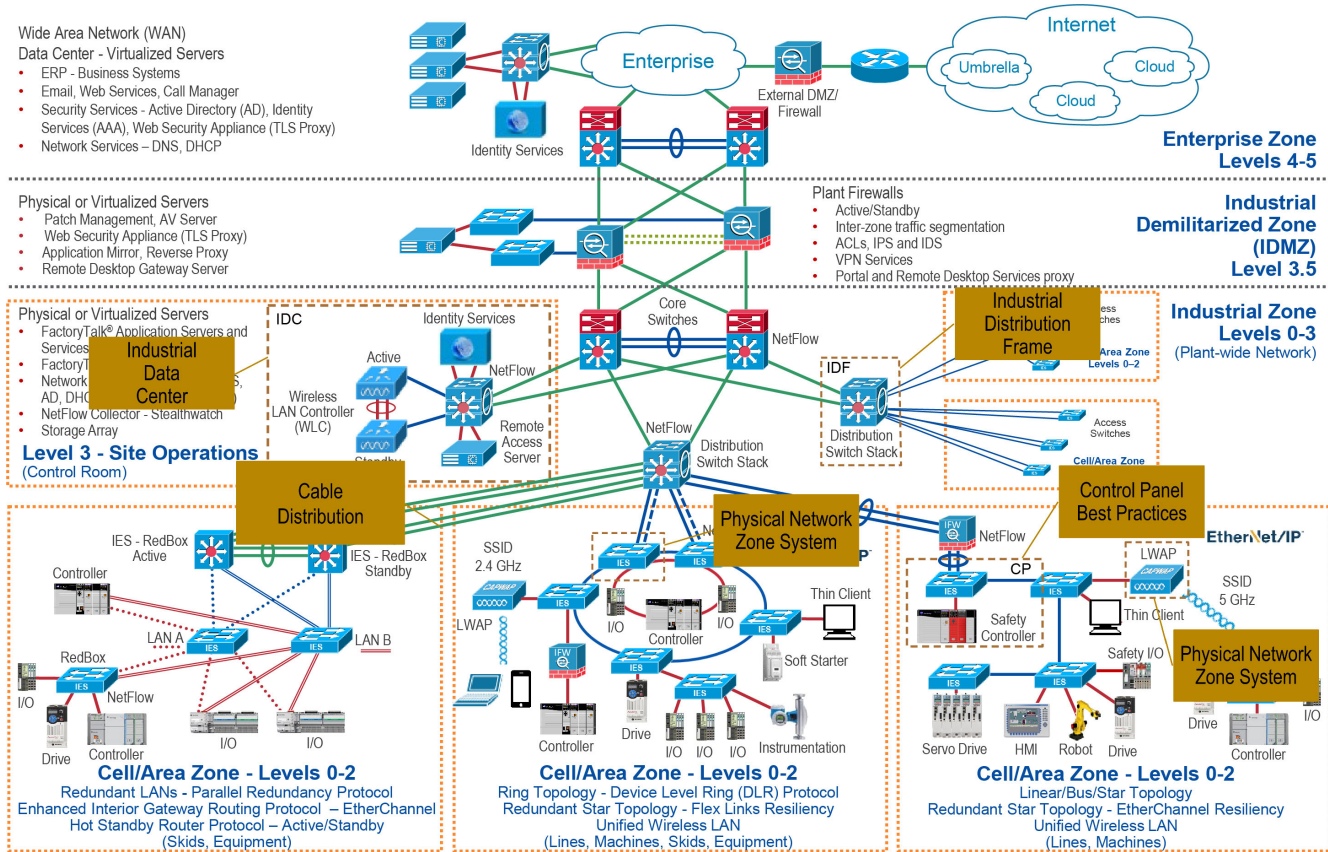

## Release Notes

This section summarizes the extensions to CPwE Resiliency in this August 2020 release:

- Test Hardware, Software, test results and reference architecture for Catalyst 9300 as distribution/aggregation switch
- Test Hardware, Software, test results and reference architecture for Catalyst 9500 as distribution/aggregation switch
- Test Hardware, Software, test results and reference architecture for Catalyst 9500 as core switch
- References to *Deploying Parallel Redundancy Protocol within a Converged Plantwide Ethernet Architecture*

This section summarizes the extensions that were added to the CPwE Resiliency February 2018 release:

- Test Hardware, Software, test results and reference architecture for Catalyst 3850 as distribution/aggregation switch
- Removal of Catalyst 3750X as distribution/aggregation switch
- References to *Deploying Device Level Ring within a Converged Plantwide Ethernet Architecture*

## Summary

CPwE is a collection of architected, tested, and validated designs. The testing and validation follow the Cisco Validated Design (CVD) and Cisco Reference Design (CRD) methodologies.

The content of CPwE, which is relevant to both operational technology (OT) and informational technology (IT) disciplines, consists of documented architectures, best practices, guidance, and configuration settings to help industrial operations and OEMs with the design and deployment of a scalable, reliable, secure, and future-ready plant-wide or site-wide industrial network infrastructure. CPwE can also help industrial operations and OEMs achieve cost reduction benefits using proven designs that can facilitate quicker deployment while helping to minimize risk in deploying new technology. CPwE is brought to market through an ecosystem consisting of Cisco, Panduit, and Rockwell Automation emergent from the strategic alliance between Cisco Systems and Rockwell Automation.

Resilient plant-wide or site-wide network architectures play a pivotal role in helping to confirm overall plant/site uptime for industrial operations. IACS application requirements such as availability and performance drive the choice of resiliency technology. A holistic and scalable resilient plant-wide or site-wide network architecture is composed of multiple technologies (logical and physical) deployed at different levels within plant-wide or site-wide architectures. When selecting resiliency technology, various IACS application factors should be evaluated, including physical layout of IACS devices (geographic dispersion), recovery time performance, uplink media type, tolerance to data latency and jitter and future-ready requirements.

The *Deploying a Resilient Converged Plantwide Ethernet Architecture Design and Implementation Guide (DIG)* outlines several use cases for designing and deploying a scalable and holistic resilient plant-wide or site-wide Industrial Automation and Control System (IACS) network infrastructure. CPwE Resiliency highlights the key IACS application requirements, technology and supporting design considerations to help with the successful design and deployment of these specific use cases within the CPwE framework. CPwE Resiliency was architected, tested and validated by Cisco Systems, Panduit, and Rockwell Automation.

More information on CPwE Design and Implementation Guides can be found at the following URLs:

- Rockwell Automation site:
  - <https://www.rockwellautomation.com/en-us/capabilities/industrial-networks/network-architectures.html>
- Cisco site:
  - [http://www.cisco.com/c/en/us/solutions/enterprise/design-zone-manufacturing/landing\\_ettf.html](http://www.cisco.com/c/en/us/solutions/enterprise/design-zone-manufacturing/landing_ettf.html)



Panduit Corp. is a world-class provider of engineered, flexible, end-to-end electrical and network connectivity infrastructure solutions that provides businesses with the ability to keep pace with a connected world. Our robust partner ecosystem, global staff, and unmatched service and support make Panduit a valuable and trusted partner.

#### [www.panduit.com](http://www.panduit.com)

US and Canada:  
Panduit Corp.  
World Headquarters  
18900 Panduit Drive  
Tinley Park, IL 60487  
iai@panduit.com  
Tel. 708.532.1800

Asia Pacific:  
One Temasek Avenue #09-01  
Millenia Tower  
039192 Singapore  
Tel. 65 6305 7555

Europe/Middle East/Africa:  
Panduit Corp.  
West World  
Westgate London W5 1XP Q  
United Kingdom  
Tel. +44 (0) 20 8601 7219

Latin America:  
Panduit Corp.  
Periférico Pte Manuel Gómez  
Morin #7225 - A  
Guadalajara Jalisco 45010  
MEXICO  
Tel. (33) 3777 6000

FiberRunner, IndustrialNet, Mini-Com, Net-Access, OptiCam, Panduit, QuickNet and Wyr-Grid are trademarks of the Panduit Corporation.

Cisco is the worldwide leader in networking that transforms how people connect, communicate and collaborate. Information about Cisco can be found at [www.cisco.com](http://www.cisco.com). For ongoing news, please go to <http://newsroom.cisco.com>. Cisco equipment in Europe is supplied by Cisco Systems International BV, a wholly owned subsidiary of Cisco Systems, Inc.

#### [www.cisco.com](http://www.cisco.com)

Americas Headquarters  
Cisco Systems, Inc.  
San Jose, CA

Asia Pacific Headquarters  
Cisco Systems (USA) Pte. Ltd.  
Singapore

Europe Headquarters  
Cisco Systems International BV  
Amsterdam, The Netherlands

Cisco has more than 200 offices worldwide. Addresses, phone numbers, and fax numbers are listed on the Cisco Website at [www.cisco.com/go/offices](http://www.cisco.com/go/offices).

Cisco and the Cisco logo are trademarks or registered trademarks of Cisco and/or its affiliates in the U.S. and other countries. To view a list of Cisco trademarks, go to this URL: [www.cisco.com/go/trademarks](http://www.cisco.com/go/trademarks). Third-party trademarks mentioned are the property of their respective owners. The use of the word partner does not imply a partnership relationship between Cisco and any other company. (1721R)

Rockwell Automation is a leading provider of power, control and information solutions that enable customers to be more productive and the world more sustainable. In support of smart manufacturing concepts, Rockwell Automation helps customers maximize value and prepare for their future by building a Connected Enterprise.

#### [www.rockwellautomation.com](http://www.rockwellautomation.com)

Americas:  
Rockwell Automation  
1201 South Second Street  
Milwaukee, WI 53204-2496 USA  
Tel: (1) 414.382.2000  
Fax: (1) 414.382.4444

Asia Pacific:  
Rockwell Automation  
Level 14, Core F, Cyberport 3  
100 Cyberport Road, Hong Kong  
Tel: (852) 2887 4788  
Fax: (852) 2508 1846

Europe/Middle East/Africa:  
Rockwell Automation  
NV, Pegasus Park, De Kleetlaan 12a  
1831 Diegem, Belgium  
Tel: (32) 2 663 0600  
Fax: (32) 2 663 0640

Allen-Bradley, FactoryTalk, FactoryTalk Network Manager, Rockwell Automation, and Stratix are trademarks of Rockwell Automation, Inc. Trademarks not belonging to Rockwell Automation are property of their respective companies.

CIP, CIP Sync, and EtherNet/IP are trademarks of ODVA, Inc.