



# Deploying a Fiber Optic Physical Infrastructure within a Converged Plantwide Ethernet Architecture

## Application Guide

January 2018

# Deploying a Fiber Optic Physical Infrastructure within a Converged Plantwide Ethernet Architecture

## Introduction

Converged Plantwide Ethernet (CPwE) is the underlying architecture that provides standard network services for control and information disciplines, devices, and equipment found in modern industrial automation and control system (IACS) applications. CPwE is a collection of tested and validated architectures that are developed by subject matter authorities at Cisco, Panduit<sup>1</sup>, and Rockwell Automation that follow the Cisco Validated Design (CVD) program. The content of CPwE, which is relevant to both Operational Technology (OT) and Informational Technology (IT) disciplines, consists of documented architectures, best practices, guidance, and configuration settings to help manufacturers with design and deployment of a scalable, reliable, secure, and future-ready plant-wide industrial network infrastructure. Connections within a CPwE architecture take many forms including copper cabling, fiber optic cabling, and wireless connectivity. This application guide provides direction for the fiber optic cabling used in a CPwE architecture.

As a data transport medium, optical fiber is an integral part of a CPwE deployment. Fiber provides the connectivity for a wide variety of connection types and offers several benefits within a CPwE architecture. By bringing the CPwE architecture to market, Cisco and Rockwell Automation help manufacturers meet the challenges of a fully-integrated IACS and realize the business benefits standard networking offers. CPwE can also help manufacturers achieve the benefits of cost reduction using proven designs that facilitate quicker deployment while helping to reduce risk in deploying new technology.

Figure 1 shows the CPwE logical framework, which incorporates all elements of a standard plant-wide network. The CPwE logical framework segments devices and equipment into hierarchical functions. This framework also identifies Levels of operations and defines logical plant network Zoning (segmentation) based on functional and security areas. In this document, the CPwE term Industrial Zone is used generically to represent applications such as IACS, process automation systems (PAS), and supervisory control and data acquisition (SCADA). This application guide can be viewed as an extension to the CPwE *Deploying a Resilient Converged Plantwide Ethernet Architecture Design and Implementation Guide* ([http://literature.rockwellautomation.com/idc/groups/literature/documents/td/enet-td010\\_-en-p.pdf](http://literature.rockwellautomation.com/idc/groups/literature/documents/td/enet-td010_-en-p.pdf)).

Plant-wide deployment of EtherNet/IP<sup>TM</sup> requires an industrial network design methodology, which helps create a structured hierarchy to support real-time network performance. In addition, it helps enable the convergence of multiple control and information disciplines, including data collection, configuration,

1. This fiber application guide.

diagnostics, discrete, process, batch, safety, time synchronization, drive, motion, energy management, voice, and video (Figure 1).

Figure 1 CPwE Logical Framework

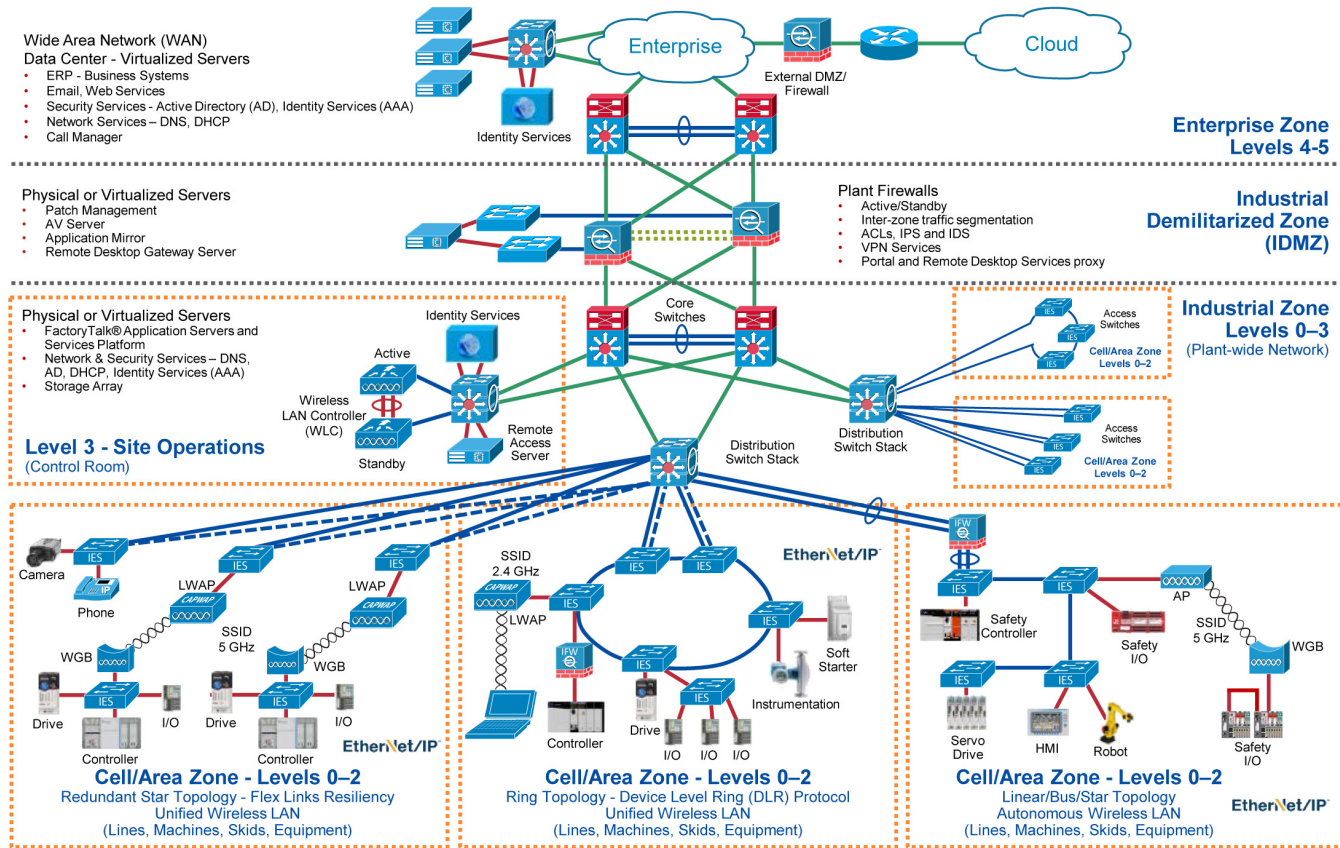

377620

## What You Will Learn

This application guide helps designers and installers select and deploy fiber optic media in plant environments. It details fiber optic network infrastructure solutions that provide high-performance connectivity options that help increase the integrity and availability of a CPwE architecture at each level of the plant-wide network. To assist designers and installers with planning and implementing a viable network infrastructure, this application guide focuses on the following three steps for selecting fiber optic cabling:

1. Determine the correct type of singlemode or multimode and, if multimode fiber is required, the correct grade of multimode fiber.
2. Determine the number of fiber optic strands needed in each cable run.
3. Select the appropriate cable construction for the environment.

In addition to cable selection, this application guide discusses the connectors, adapters, and patching required for a structured cable deployment. It also explains selection and best practice applications for cable management, pathways, and fiber optic enclosures.

## Fiber Optic Cabling Systems Overview

A fiber optic network generally comprises multiple pieces of equipment interconnected by optical fiber cabling assemblies. The fiber channel is the fiber optic connection between one piece of equipment and another and includes the entire fiber assembly. Each channel consists of a pair of fibers that form an individual circuit, with each circuit having a transmit fiber (typically labeled TX) and a receive fiber (typically labeled RX). When configured this way, the optical fiber assemblies in this channel become a duplex type supporting separate transmit and receive circuits.

The CPwE architectures subject matter authorities recommend the use of optical fiber links between network switches in the Industrial Zone for the following applications:

- Redundant paths for high availability— ring and redundant star
- Optimal resiliency protocol convergence times for switches
- Electromagnetic noise immunity
- Distance and outdoor cable runs

Figure 2 LC Duplex Patch Cord



Various approaches can be used to configure the channel. For example, a duplex patch cord (Figure 2) may be used to connect two pieces of equipment that are in close proximity to each other. Attention must be given to achieve the correct polarization of the connections, i.e., that the transmit (TX) port of one device attaches to the receive (RX) port of the other piece of equipment and vice versa. This polarization is accomplished by patch cord construction and standardized keying of the connectors.

Figure 3 Permanent Link Diagram

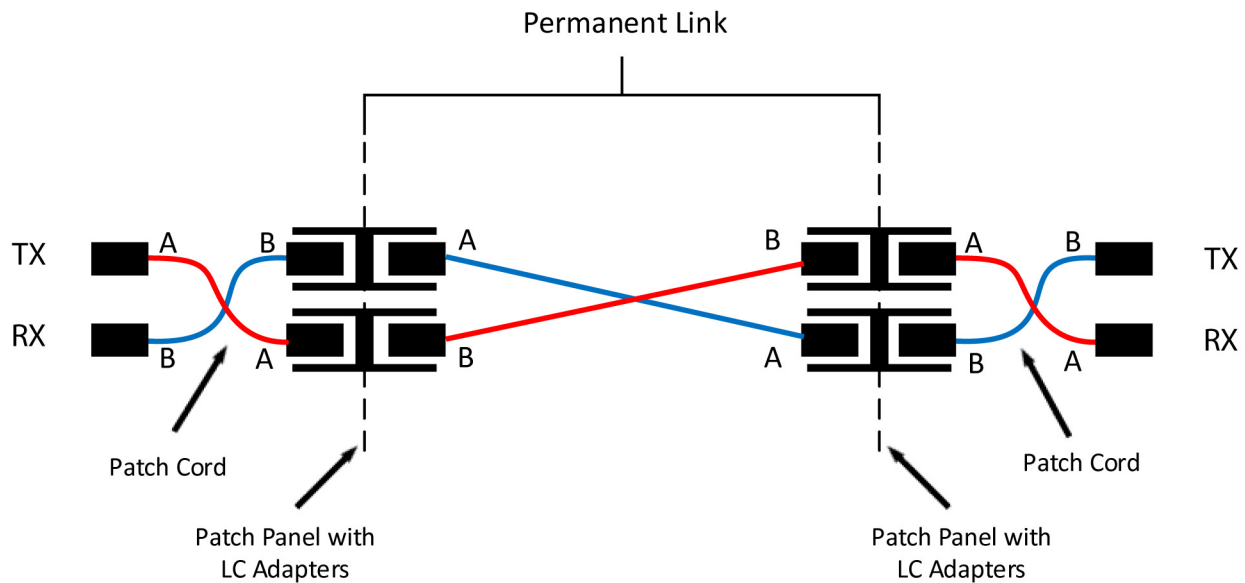

377814

The typical channel is composed of multiple assemblies connected by a combination of the optical fiber connectors on the cable assemblies mating into adapters. The adapters are mounted into patch panels or other types of mounting arrangements that provide a mechanically convenient and secure point for the connection.

Optical fiber systems deployed in local area network (LAN) applications do not use the same fiber for transmit and receive, which means that the transmit port of one piece of equipment must be connected to the receive port of the neighbor—commonly known as A to B. The A to B connection must be made in the permanent link and patch cords to confirm correct operation, as shown in [Figure 3](#).

This section discusses the available options and selection and installation considerations for fiber optic cabling systems, which include:

- [Selecting Singlemode or Multimode Fiber](#)
- [Selecting the Number of Fiber Optic Cabling Strands](#)
- [Environmental](#)
- [Cable Designs](#)
- [Fiber Connectors](#)
- [Network Convergence Time](#)
- [Fiber Optic Loss/Power Budgets](#)
- [Fiber Cable Management](#)
- [Media Selection:](#)
  - [Cell/Area Zone Fiber Optic Cabling Types](#)
  - [Industrial Distribution Frame Fiber Optic Cabling Types and Products](#)
  - [Level 3 Site Operations Fiber Optic Cabling Types](#)
  - [Patch Cords](#)

## Selecting Singlemode or Multimode Fiber

There are two different types of fiber used in connecting networks, singlemode and multimode, which vary by glass core size and by the design and operation of the transceivers used. Multimode fiber is commonly used for shorter transmission distances due to the cost efficiency it offers. Singlemode fiber uses more precise transceivers to achieve longer transmission distances and is more costly to implement than multimode fiber. Designers and installers need to make sure that the transceiver type and fiber type are compatible for optimal performance.

Multimode optical fiber incorporates a larger core diameter than singlemode fiber type. In addition, the core diameter used in multimode fiber varies depending upon the performance type used. For example, OM1 (optical multimode 1) was the first type of multimode fiber to be deployed and uses a 62.5 $\mu$ m core diameter with an overall cladding diameter of 125 $\mu$ m. This fiber type is almost never deployed in new installations, but may be required for legacy installations with an installed equipment base. Multimode fiber types OM2, OM3, and OM4 are based on the use of a core diameter of 50 $\mu$ m (again with a cladding diameter of 125 $\mu$ m) and offer improved performance in terms of maximum channel length. OM4 is recommended for new installations and represents the best available compromise between total link cost (optical fiber plus transceivers) and channel length.

Singlemode fiber types used in plant network applications have a core diameter of 9 $\mu$ m and a cladding diameter of 125 $\mu$ m. The transceivers used with singlemode fiber incorporate more costly laser sources and so the overall link cost is higher than multimode fiber, however longer channel lengths can be realized. There are two common designations for optical singlemode (OS) fiber, identified as OS1 and OS2. OS1 is a legacy fiber type and is not recommended for any deployment, though it may be seen in legacy deployments. OS2 is the default singlemode fiber designation, though literature commonly calls this OS1/OS2.

Figure 4 shows a schematic diagram of the different optical fiber constructions and the designations for each fiber type are listed in Table 1.

Table 1 Maximum Distance for Currently Used Fiber Types and Designations

Designation	Core/Cladding Diameter	Fiber Type	100 Mbps Maximum Distance	1 Gbps Maximum Distance
OM1	62.5/125 $\mu$ m	Multimode	2000m	220m
OM2	50/125 $\mu$ m	Multimode	2000m	275m
OM3	50/125 $\mu$ m	Multimode	>2000m	500m
OM4	50/125 $\mu$ m	Multimode	>2000m	550m
OS2	9/125 $\mu$ m	Singlemode	10km	10km

Figure 4 Comparison of Fiber Cores for OM1-OM4 and OS2

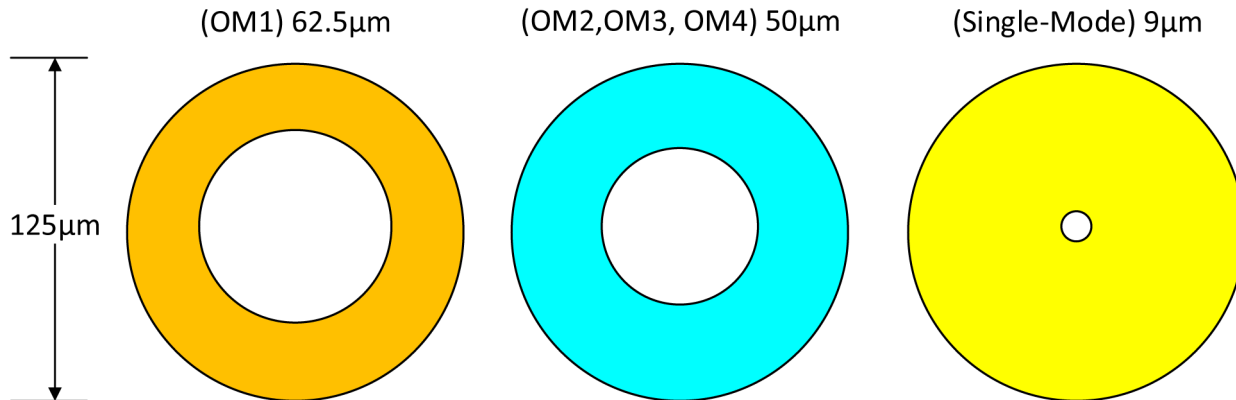

377815

## Selecting the Number of Fiber Optic Cabling Strands

Multi-stranded fiber optic cabling assemblies are available with numerous strand counts. Commonly used counts include 2, 6, 12, 24, and 36 strands. The number of strands required for an optimal deployment equates to the number of pairs required for switches and devices that must be connected and includes a factor for growth. For example, connecting three access switches in close proximity to a distribution switch in a different location requires six strands because each access switch requires two strands for transmit and receive. Additional strands should be included for future growth and the possibility of failed fiber strands. To determine the total number of strands, combine the required strands, future growth, and spares. For this example, a twelve-strand fiber cable is the proper choice.

## Environmental

Fiber optic cabling in IACS environments can encounter caustic, wet, vibrating, and electrical noise conditions. Therefore during physical layer design, designers should assess these environmental factors in each area where the network is to be distributed (Figure 5).

Figure 5 Sample Environmental Analysis Using the MICE System

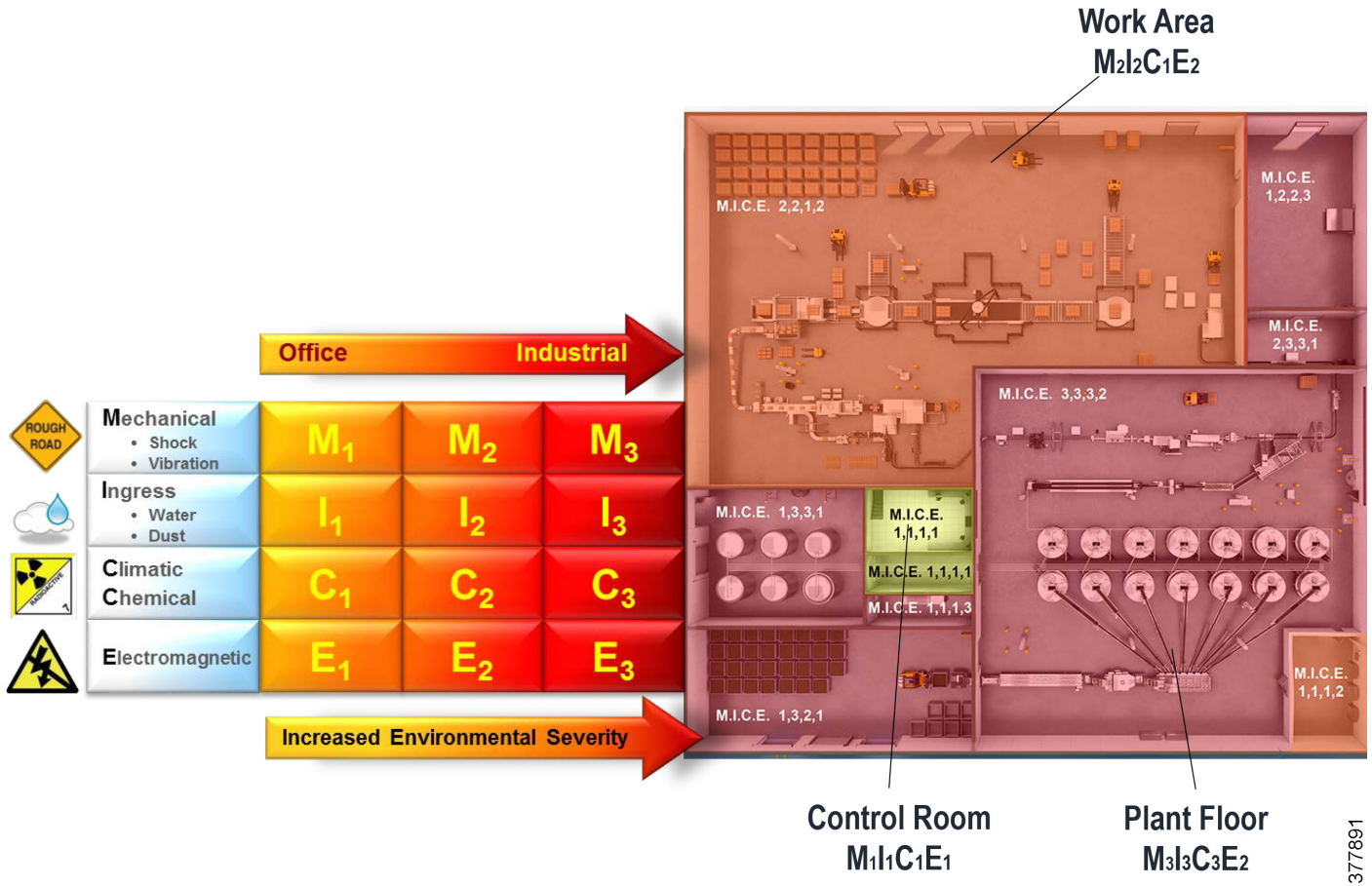

The Mechanical, Ingress, Chemical/Climatic, and Electromagnetic (MICE) system is an assessment tool that evaluates these specified risk factors in each zone of a generic cable plant. MICE diagramming allows the design to balance component costs with mitigation costs to build a robust yet cost-effective system. Each MICE factor is graded on a severity scale ranging from 1-3. MICE criteria allow the designer to select appropriate media (such as armored fiber) or protective pathway arrangements that avoid risks from the environment affecting performance or reliability. Qualifying the exposure levels allows designers to specify appropriate connectivity and pathways to enable long-term performance. For example, exposure to shock, vibration, or ultraviolet (UV) light may require use of armored fiber cabling suitable for outdoor environments.

For this assessment, consider using MICE analysis, a method recommended by global standards groups such as ANSI/TIA-568-D.0 and ODVA, Inc. EtherNet/IP Media Planning & Installation Manual ([https://www.odva.org/Portals/0/Library/Publications\\_Numbered/PUB00148R0\\_EtherNetIP\\_Media\\_Planning\\_and\\_Installation\\_Manual.pdf](https://www.odva.org/Portals/0/Library/Publications_Numbered/PUB00148R0_EtherNetIP_Media_Planning_and_Installation_Manual.pdf)).

. A tutorial on this analytic tool is found in TIA TSB-185 - Environmental Classification (MICE) Tutorial.

## Cable Designs

This section discusses the four basic fiber optic cable designs for plant-wide network applications:





- Indoor Distribution



- Armored Distribution
- Dielectric Conduited Fiber (DCF)

Table 2 illustrates transmission speed and suitable fiber media types. Reading from left to right, the various fiber selections increase in environmental severity.

Table 2 Fiber Types with Details

Core Diameter	Maximum Distance Per Standards, meters	Fiber Type			
		Distribution	Dielectric Conduited Fiber	Indoor Armored	Gel Free Outside Plant Armored
62.5µm	2000	 FSDR6 <sup>YY</sup>	 FSAD6 <sup>^^</sup>	 FSPR6 <sup>YY</sup>	 FSWNG6 <sup>^^</sup>
50µm	2000	FSDR5 <sup>YY</sup>	FOADX08	FSPR5 <sup>YY</sup>	FSWNG5 <sup>^^</sup>
9µm	10000	FSDR9 <sup>YY</sup>	FSAD9 <sup>^^</sup>	FSPR9 <sup>YY</sup>	FSWN9 <sup>^^</sup>
62.5µm	275	FSDR6 <sup>YY</sup>	FSAD6 <sup>^^</sup>	FSPR6 <sup>YY</sup>	FSWN6 <sup>^^</sup>
50µm	500	FSDR5 <sup>YY</sup>	FOADX08	FSPR5 <sup>YY</sup>	FSWN5 <sup>^^</sup>
50µm (10Gig)	550	FODRX <sup>YY</sup>	FOADZ <sup>^^</sup>	FOPRX <sup>YY</sup>	FOWNX <sup>^^</sup>
9µm	10000	FSDR9 <sup>YY</sup>	FSAD9 <sup>^^</sup>	FSPR9 <sup>YY</sup>	FSWN9 <sup>^^</sup>

377819

## Fiber Application

Although there are many types and constructions of optical fiber, this discussion focuses on Industrial Zone applications where there are four main fiber types that are commonly deployed in IACS networks. These fiber types can vary greatly depending on the type of deployment, design concerns, environment in the Industrial Zone, etc. They are identified according to typical areas of use:

- Indoor Distribution—Typically used in the Enterprise Zone and suitable points in the Industrial Zone, e.g., to the Level 3 Site Operations Industrial Data Center (IDC).
- Armored Distribution—A variation of the cabling type in Indoor Distribution, it is used in Industrial Zone areas where continuous pathways are not available and is desirable since the armored cable provides protection normally obtained by routing in continuous pathways. This fiber type will typically be routed from the IDC to the Physical Network Zone System (PNZS) or the IACS control panels.
- Dielectric Conduited Fiber (DCF)—An attractive option when using a smaller number of fibers that might be seen closer to the PNZS or control panel in the Industrial Zone and is used in situations similar to Armored Distribution. A more detailed description of DCF is in [Industrial Distribution Frame Fiber Optic Cabling Types and Products](#).

Table 3 gives additional selection information for the different fiber types within IACS network deployments.

Table 3 Selection Information for Fiber Types within IACS Network Deployments

	Indoor Distribution	Metal Armored Distribution	Dielectric Conduited Fiber
Most frequent area of use	Within the Enterprise Zone and Level 3 Site Operations	Typical light Industrial Zone environment pathways using J-hooks or other non-continuous approaches	Typical light Industrial Zone environment pathways using J-hooks or other non-continuous approaches
Most typical level of use in CPwE architecture	3, 4, 5	Connections between 3 and 2, Cell/Area Zone	Connection between 3 and 2, Cell/Area Zone
Mode types	OS2, OM1-OM4	OS2, OM1-OM4	OS2, OM1-OM4
Typical range of individual fibers	2-144	2-144	2, 4, 6, 8, 12
Support required?	Continuous/closely spaced discontinuous	Discontinuous, e.g., J-hooks, 5' (1.52m) spacing	Discontinuous, e.g., J-hooks, 5' (1.52m) spacing
Grounding provisions required?	No	Yes	No

## Fiber Construction for Indoor or Outdoor Use

The most common construction for optical fiber for indoor use is called tight buffer, where a protective coating surrounds the cladding and an additional jacket of polyvinyl chloride (PVC) brings the diameter of the individual fiber to 900µm. Multiple fibers are wrapped with a protective Aramid yarn. The entire cable assembly is coated in a durable external jacket, typically polymer material, that is riser, plenum, or otherwise rated to suit the installation environment.

Tight buffered fiber is not deployed in outdoor environments because the temperature extremes and mechanical stresses encountered in outdoor installations can cause physical degradation or even damage to the fiber. An alternate construction, loose tube, is used for fiber deployments in outdoor environments. The loose tube design consists of the individual fibers (before the PVC coating is applied) which “float” within a polymer tube allowing it to move yet be protected when the fiber is subject to movement. Older cable designs also use a water blocking gel inserted into the tube to help protect the fiber from both damage and moisture ingress. Newer indoor/outdoor cable types include a water absorptive tape underneath the exterior jacket that swells and forms an effective seal if the jacket is ruptured.

Examples of the construction of the tight buffered and loose tube fiber types are shown in [Figure 6](#) and [Figure 7](#).

Figure 6 Tight Buffered Fiber Type

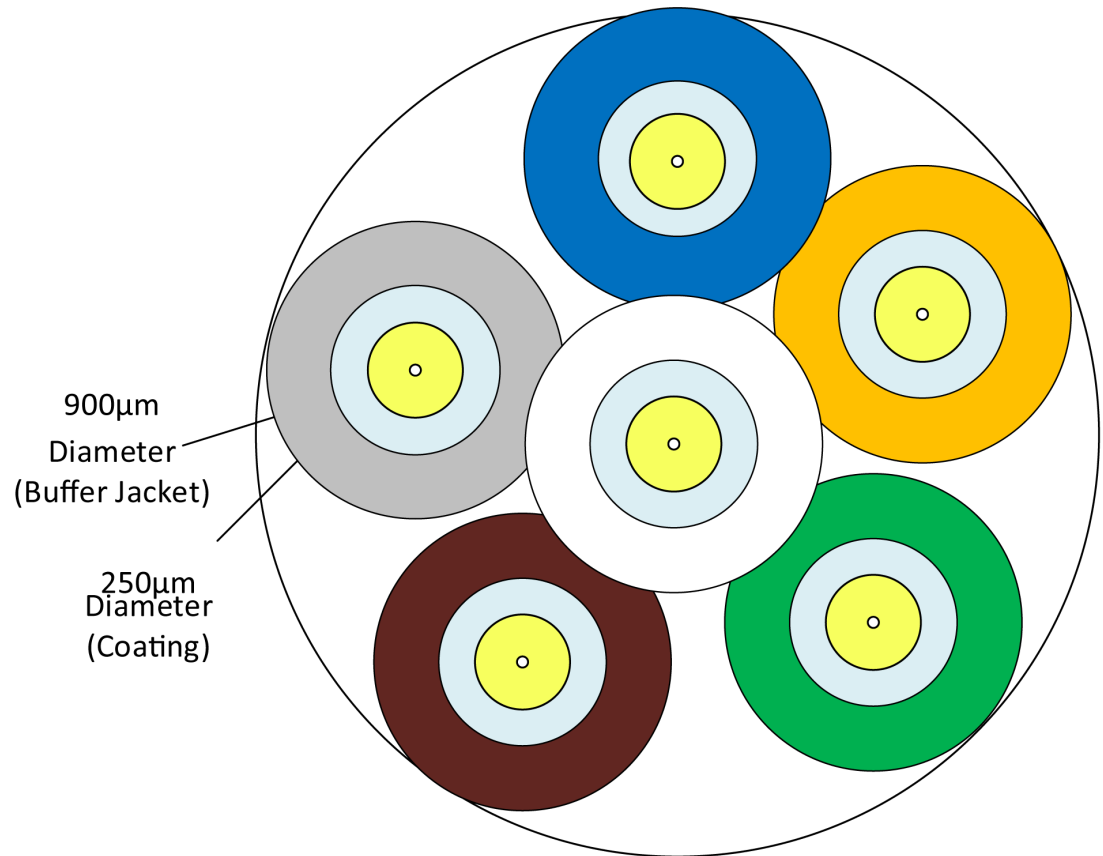

377816

Figure 7 Loose Tube Fiber Type

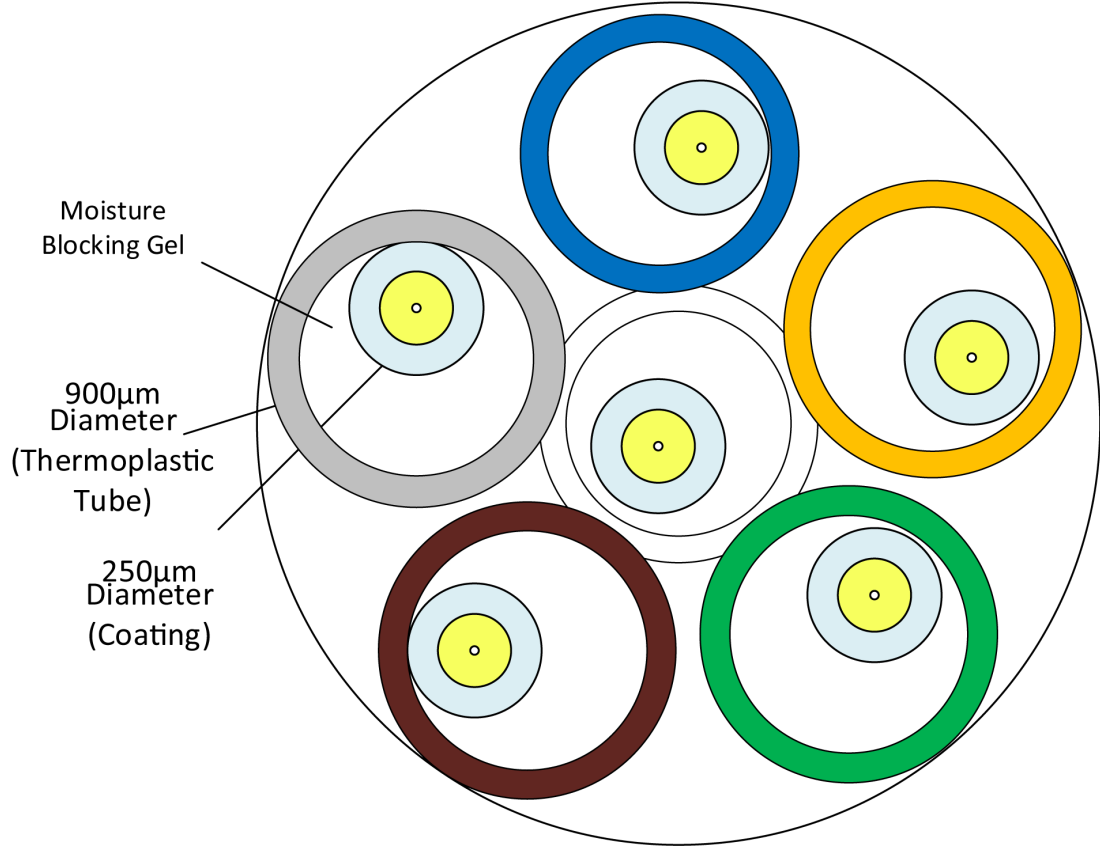

377817

## Distribution Fiber Optic Cabling (Non-armored)

Non-armored distribution fiber optic cabling (Figure 8) is a standard cable that runs in a cabling basket, cable ladder, or conduit in an indoor environment. Non-armored distribution fiber optic cabling requires protection, therefore, at a minimum, it should be installed in a duct or continuously supported system depending on the environment. It may also require greater environmental hardening depending on the harshness of the environment (e.g., in conduit).

This cabling type is used in the intra-building backbone, building backbone, and horizontal installations for riser (OFNR), plenum (OFNP), and general-purpose environments. Riser and plenum-rated fiber optic cable are most commonly used in North America. Other regions of the world, (e.g., Europe and Asia Pacific) require optical fiber with a low smoke zero halogen (LSZH) rated cable jacket. Always consult the local codes and standards for the plant location to be certain the proper variant is selected during the design stage. This topic is discussed in more detail in [Level 3 Site Operations Fiber Optic Cabling Types](#).

Figure 8 Distribution Fiber Optic Cabling (Non-Armored)

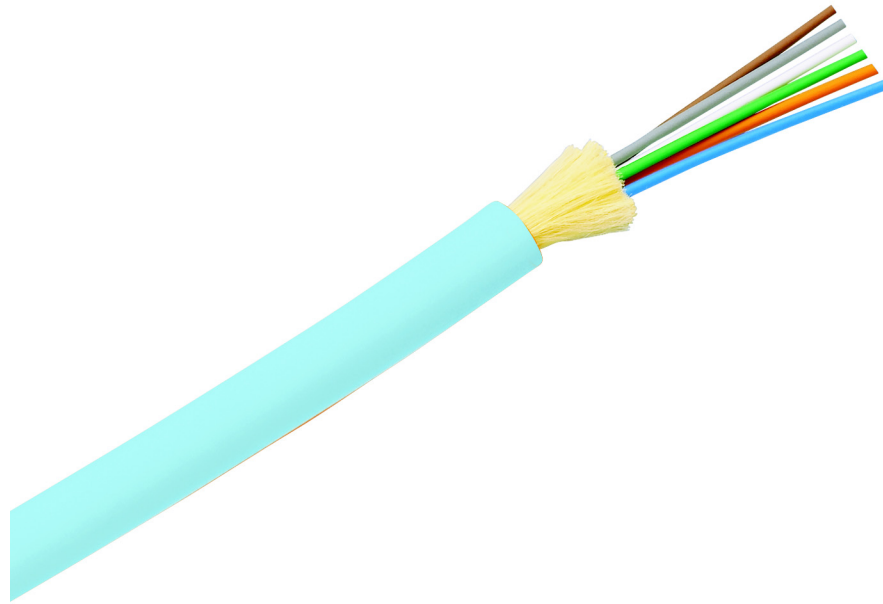

377790

Figure 9 IP-rated OSP/IO Fiber Optic Cabling

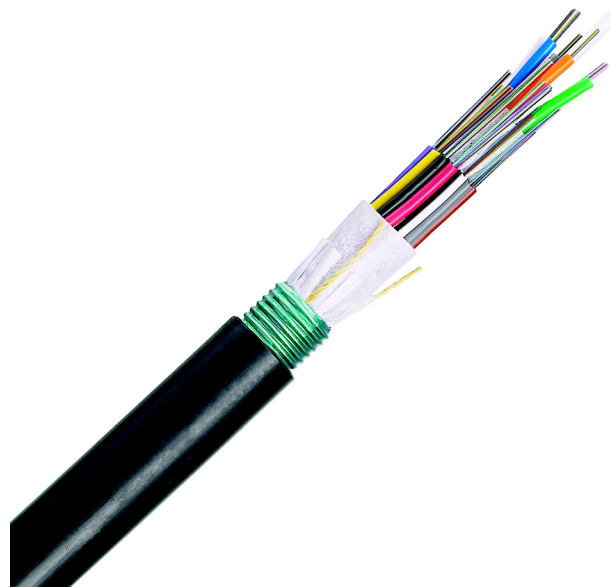

377791

## IP-rated (Outside Plant/Indoor and Outdoor) Fiber Optic Cabling

IP-rated fiber optic cabling (outside plant/indoor and outdoor) is rated for high temperatures, is chemically resistant, and can be used in harsh environments (Figure 9). These fiber cables incorporate loose tube construction making them suitable for aerial, duct, and direct burial applications. There are two types of

ingress protection: gel and gel-free. Although the gel helps to protect the fibers and prevent moisture ingress, it becomes sticky and messy when handled. Gel-free designs are easier to handle and have tape that swells in contact with water to provide dry water blocking.

A corrugated steel armoring over the polymer jacket protecting the fibers provides high crush resistance for increased durability in direct burial applications. A UV resistant cable sheathing is often used in these applications to protect the individual fiber cable. As in the case of the indoor cable described above, outside plant/indoor and outdoor cable is available in 6, 12, 24, 36, 48, 72, 96, and 144-fiber counts. This cable construction also supports multimode (OM4, OM3, OM2, and OM1) and singlemode (OS2) fiber types.

## Interlocking Armored Fiber Optic Cabling

Interlocking armored fiber optic cabling (both indoor and outside the plant) has a protective aluminum or metal housing around the fiber cable to provide superior crush resistance and guard the cabling from animal intrusion (Figure 10). Aluminum interlocking armor also eliminates the need for inner duct or conduit with a smaller pathway for improved design flexibility and lower installed cost. In addition, these cables permit easy retrofit into existing industrial environments, removing the need for sophisticated and expensive pathways.

Armored fiber optic cabling types are used in the intra-building backbone, building backbone, and horizontal installations for riser (OFCR), plenum (OFCP), and harsh environments. The cables are available in 6, 12, and 24-fiber counts in a “single jacket” design and in 36, 48, 72, 96, and 144-fiber counts in a “subunit” (group) design. For higher fiber count types, depending upon the construction, subunits of fibers are housed within internal jackets inside the overall cable jacket to facilitate identification and installation. Multimode (OM4, OM3, OM2, and OM1) and singlemode (OS2) fiber are widely available.

Figure 10 Armored Fiber Optic Cabling

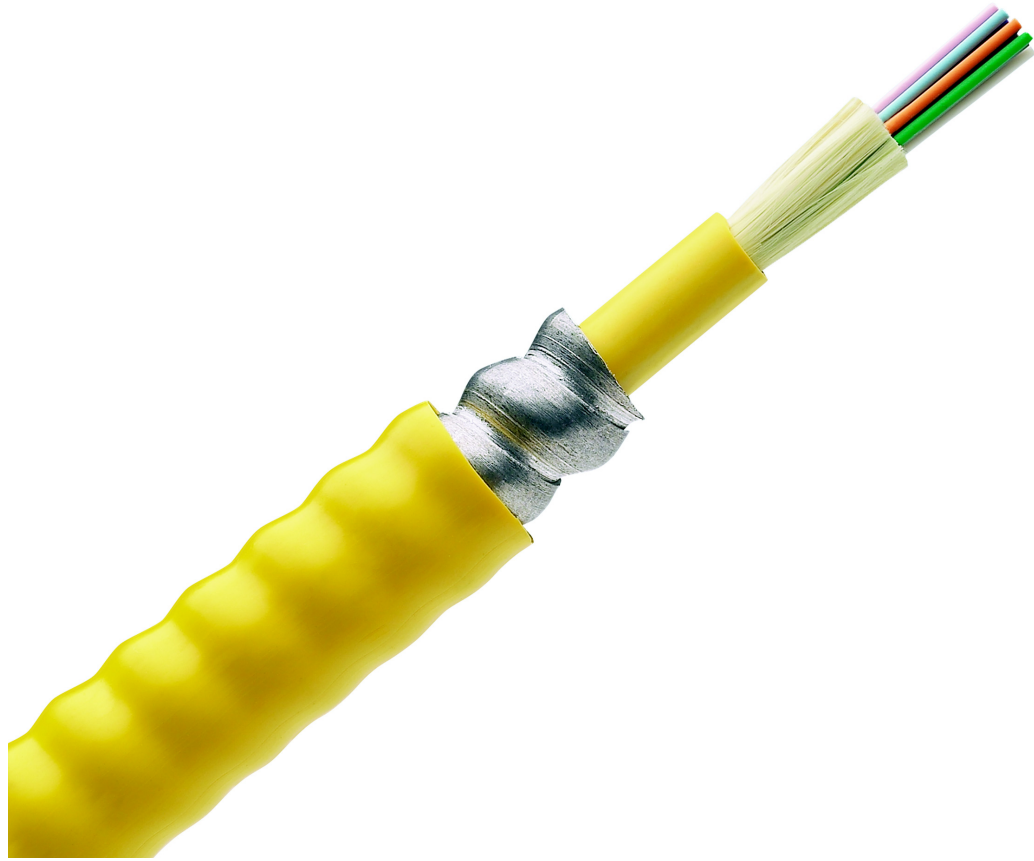

377792

## Fiber Connectors

Connectors are the physical interface between the cabling and networked devices. There are several connector types used in the network physical infrastructure. This section discusses three connector types commonly encountered when fiber optic cable is used in industrial networks:

- Lucent (LC)
- Subscriber (SC)
- Straight Tip (ST)

The characteristics of the three connector types are summarized in [Table 4](#).

### LC Connectors

LC connectors are used in data center environments and many IACS devices. They have a small footprint that allows them to be used on high port count switches and on devices, minimizing the space required to land these connections. The LC connector footprint is approximately half the size of an SC connector and has a back shell designed to accommodate standard 1.6mm to 3.0mm diameter cable designs. The LC connector interface presents a small form-factor pluggable (SFP) demountable interface for connection to SFP transceivers. The standard construction of the LC connector consists of a spring-loaded, 1.25mm diameter

zirconia ceramic ferrule housed in a thermoplastic connector back shell. The dimensions for this connector are defined in both domestic (TIA-604 FOCIS-10) and international (IEC 61754-20) standards. Of the three connector types identified in this section, the LC connector is most used due to its high performance and small size, allowing the highest connection densities to be obtained.



## SC Connectors

SC connectors are snap-in connectors that are widely used in singlemode fiber optic cabling systems. These connectors are used in the data communication and telecommunication industries but are losing ground to LC and other connector types. One reason is their larger size, which prevents them from being used in high-density applications. Despite this limitation, SC connectors have a strong presence in the enterprise market where high density is not an issue.

## ST Connectors

ST connectors are bayonet style connectors that create secure multimode connections. The ST connector is used for inline connections, however some equipment uses ST connectors because of the mechanical stability of the connection.

Table 4 Fiber Optic Connector Comparison Summary

	LC	SC	ST
Image			
Connector Name	Lucent or Little (LC)	Square or Subscriber (SC)	Straight Tip (ST)
Coupling Type	Snap	Snap (Push-Pull)	Bayonet
Connector Outside Dimensions, mm	4.5 x 4.5	9.0 x 8.3	Diameter 8.6
Ferrule size, mm	1.25	2.5	2.5
TIA Standard	TIA-604/FOCIS - 10	TIA-604/FOCIS - 3	TIA-604/FOCIS -2
IEC Standard	IEC 61754-20	IEC 61754-4	IEC 61754-2
Duplex Type	Yes, with duplexing clip	Yes. Connector can mate	No



**Note**

The ODVA, Inc. EtherNet/IP specification for the physical layer (Chapter 8) states that the LC connector is preferred for new installations requiring 100 Mbps data rates, though SC and ST connector types are supported. It also states that the LC connector is preferred for new installations requiring 1000 Mbps (1 Gbps) data rates, though SC connector types are allowable for legacy installations.

## Horizontal Cable Fiber Connector Termination

Fiber cable is attached to connectors using a variety of methods. Decision criteria are ease of installation, cost, and performance. The three main methods are:

- Fusion splice onto a fiber pigtail
- Field application of epoxy and field polish
- No epoxy, no polish

## Fusion Splicing

For this approach, the connector is factory terminated onto a short length of the same fiber type that is used in the field cabling, forming an assembly called a pigtail. The optical fiber to be terminated is prepared on site and, along with the free end of the pigtail fiber, it is placed into a piece of equipment known as a fusion splicer that contains a heating element. The silica is melted to solidify and fuse the fibers together to make a very reliable and high performing fiber joint. A protective splice tube is placed over the area of the joint and tube loaded into a splice tray holder that provides mechanical protection for the joint. The splice tray is frequently a 19-inch rack mounted unit that can be conveniently accessed should moves, adds, and changes (MACs) be necessary. The splice tray usually incorporates slack spools onto which the excess fiber can be routed for good cable management and protection.

## Field Application of Epoxy and Polish

For this method, the fiber to be terminated in place is prepared, fed into the required connector, and extended through the front face of the connector. An epoxy is loaded into an aperture in the connector and cured to firmly fix the fiber into the connector. Excess fiber is removed from the connector front face and field polished with a grinding puck and paste to form a reliable interface. The front end of the fiber is inspected using a small microscope called a borescope to achieve a high connection performance. The connector can be loaded into a fiber adapter that is located in a fiber enclosure. The excess buffered individual fibers are managed on slack spools in the enclosure.

## No Epoxy, No Polish

More recently, termination techniques that use connectors already loaded with a short length of optical fiber and factory prepared with high accuracy faces have been introduced. The connector includes a gel to achieve lowest attenuation between the pre-loaded and installed fiber. The fiber to be terminated is prepared by stripping off the buffer and cut using a special cleaver that results in a clean fiber end. The fiber is installed into the rear of the connector and locates against the rear of the pre-installed fiber length. At the correct point in the termination procedure, a cam on the connector is rotated to lock the installed fiber into place. In modern termination tools, such as the Panduit OptiCam™ tool shown in [Figure 11](#), an internal light source (the visual fault locator) shows the performance of the connection just made. An effective termination has been created if little or no light can be seen through a window in the connector.

Figure 11 Panduit OptiCam Tool



The terminated fiber is installed into a fiber adapter and managed in the same way as the field epoxy, field polish connector scheme described above.

**Note**

To help achieve worker and equipment safety, it is important to adhere to proper procedures when handling fiber optic cabling. For more information on fiber optic cable handling and safety, refer to [Appendix A, “Fiber Optic Cable Handling and Safety.”](#)

## Network Convergence Time

Network convergence time measures how long it takes to recover from both link loss and industrial Ethernet switch (IES) power disruption. For resilient network link loss (e.g., a Resilient Ethernet Protocol [REP] ring), the convergence time (i.e., healing, recovery, etc.) measures how long it takes to detect a fault, find an alternate path, and forward network traffic across that alternate path. Industry experts agree that fiber optic cabling provides ideal network convergence times in ring topologies. For IES disruptions (e.g., power loss) in resilient networks, convergence time measures how long it takes to detect the loss of the IES and reconfigure operational IES forwarding tables to work around the loss of an IES.

During the network convergence time, the network drops traffic because interconnectivity has been interrupted. If the convergence time is longer than the Allen-Bradley® Programmable Automation Controller (PAC) connection timeout, the PAC may temporarily drop its connection to its EtherNet/IP devices which may result in downtime and lost production.

**Note**

Network convergence times vary based on the IES platform, resiliency protocol, and port type.

## Fiber Optic Loss/Power Budgets

It is critical to verify that the transmitted optical signal has sufficient power when it reaches the receiver and the receiver has adequate sensitivity to decode the optical signal. The first step of the verification process is calculating the optical loss and power budgets to determine whether the design and deployment meet IEEE 802.3 specifications. This calculation is known as the overall power budget for an optical channel link and is determined using an optic loss budget calculation based on the IEEE 802.3 standard. The standard considers the combination of transceiver technology and the fiber cabling type and connectors.

Signal loss, termed attenuation, occurs in the cable itself, mated connectors, splices, splitters, and other optical components as shown in [Figure 12](#). The optical power loss of components and cabling is found in their respective specifications. For example, a typical mated LC connector pair is estimated to attenuate the optical signal by 0.75 dB. All optical losses between devices must be totaled to assess signal loss, which is the loss component of the calculation.

The next step is to calculate the transceiver power budget, which has two parts:

- Transmitted Power
- Receiver Sensitivity

These values are expressed in decibels (dB), where the difference between the transmitted power and the receiver sensitivity is the optical power budget. The transmitted power and receiver sensitivity vary by manufacturer. Both transceivers in the channel must be assessed and can be from different manufacturers.

The accumulated media and connector loss must exceed the transceiver power budget by an acceptable margin (e.g., 0.5 dB or more) to help achieve reliable communications. The margin is calculated by subtracting the total optical loss from the transceiver power budget. If the calculated value is below the margin, consider a higher power transceiver to increase the budget, evaluate the design to determine if connectors can be removed, replace connector terminations with a pigtail splice to the cable, use a different cable with less optical loss, or shorten the run.

Since this calculation is only an estimate, the actual optical power should be field tested. Field testing of the channel can be performed using a power meter/light source (PMLS) meter.

**Note**

---

Field test data can be different than the estimate due to poor connector termination, sharp bends in cable, and care used in splicing cable.

---

For more information, refer to the following link for examples of how to calculate fiber optic loss budgets: <http://www.thefoa.org/tech/lossbudg.htm>.

Figure 12 Illustration of Loss Across Fiber Optic Cabling Channel

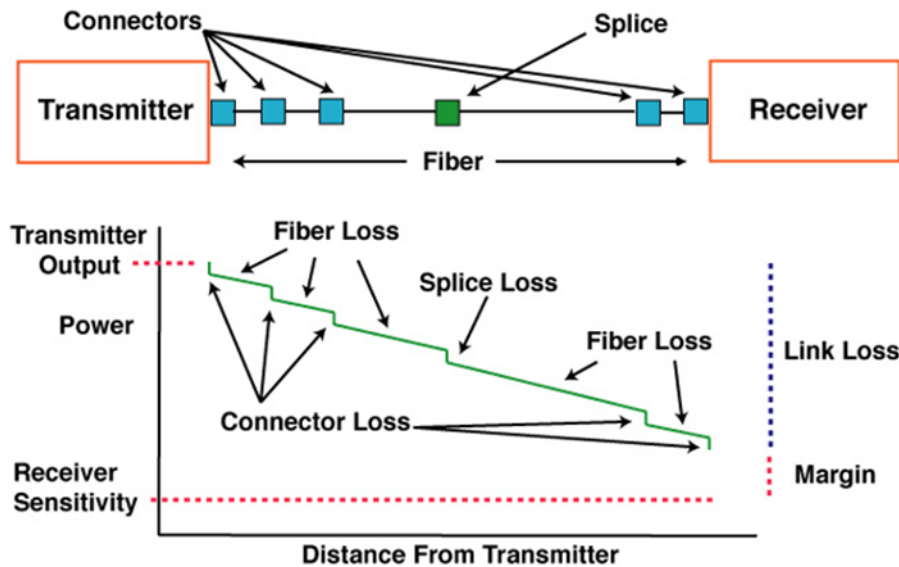

377794

## Fiber Cable Management

Proper fiber cable management is essential for high system performance, availability, and reliability. A strong cable management system helps protect the fiber optic cabling from excessive bend, flexing, sagging, rubbing, crush, etc. Effective cable management designs include the following key elements:

- [Bend Radius Control](#)
- [Cable Routing and Protection](#)
- [Patching](#)
- [Bundling Fiber Optic Cable](#)
- [Fiber Optic Cable Identification](#)

### Bend Radius Control

When fiber optic cabling must bend to go around corners or avoid obstructions, it is important to have a bend radius greater than or equal to the manufacturer's specified minimum bend radius. This provision prevents excessive bending, which can cause physical damage to the cabling.

There are two considerations for bend radius control:

- Dynamic—Cable flexing (especially during installation)
- Static—Cable held in place

Fiber cable manufacturers specify both radiuses. For example, the dynamic bend radius can be 20 times the Outer Cable Diameter (OD) and the static bend radius is typically 10 times the OD. Although fiber strands are very thin and made of glass, the strand is durable and can withstand some flexing. However, flexing can cause deformities in the fiber (called microbend), leading to signal loss over time. Therefore, the stricter bend radius is dynamic.

Another risk to a properly terminated and validated fiber cable is attenuation due to excessive cable bend in static applications (called macrobend), which is a too-tight bend that allows the light to escape the glass, reducing signal strength. Since the bend radius is based on the OD, the minimum bend radius for the application can vary. For example, a fiber patch cord cable has a static bend radius of 1.1 inch while a 12-fiber distribution cable has 2.4-inch bend radius. Bend radius is maintained by mechanical aids such as fiber spools, clips, fins, and product features built into pathways as well as proper coiling (Figure 13).

Figure 13 Coiled Slack Loop



377795

In a 19-inch style computer or switch rack/cabinet, bend radius accessories can be installed to route fiber cable vertically and horizontally. Fiber enclosures and boxes typically have built-in slack spools. Also, supplied adhesive backed clips secure the cabling and provide strain relief. Figure 14 and Figure 15 show a fiber enclosure with slack spools.

Figure 14 Fiber Enclosure Showing Slack Management—1

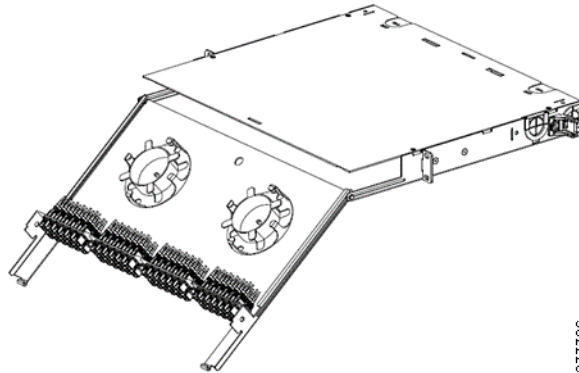

377796

Figure 15 Fiber Enclosure Showing Slack Management—2

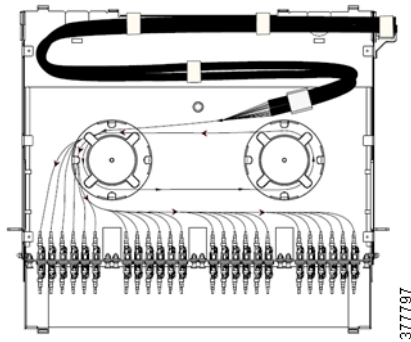

## Cable Routing and Protection

Often, fiber distribution cable is routed through conduit for protection. Although conduit is an excellent safeguard, it is designed for power wiring and has fittings, junction boxes, etc. where fiber cable under some tension can potentially bend the fiber beyond the allowable bend radius.

Pathways such as cable trays and J-hooks have challenges with sagging and bends that can attenuate the signal, especially for unprotected standard distribution cable. To avoid these installation-related losses, the cable must be supported and bends must be controlled. Draping unprotected distribution cable over J-hooks or laying the cable over an open tray with grids can lead to fiber sagging below the minimum bend radius. To avoid this risk, fiber optic cabling can be pulled through corrugated loom tube as shown in [Figure 16](#) to provide needed rigidity and support. Fibers held in interlocking armor or DCF do not encounter these issues because the armor provides support and restricts the bend radius.

Figure 16 Horizontal Cable Protection with Corrugated Loom Tubing



Another challenge to pathways is a change in direction when cables are routed down and sideways. Pathways such as the Panduit Wyr-Grid<sup>®</sup> Overhead Cable Tray System have waterfall and intersection bend radius components to properly route cables and achieve proper bend radius ([Figure 17](#), [Figure 18](#), and [Figure 19](#)). These components snap onto the Wyr-Grid Overhead Cable Tray System where the fiber cable needs to bend.

Figure 17 Wyr-Grid Overhead Cable Tray System

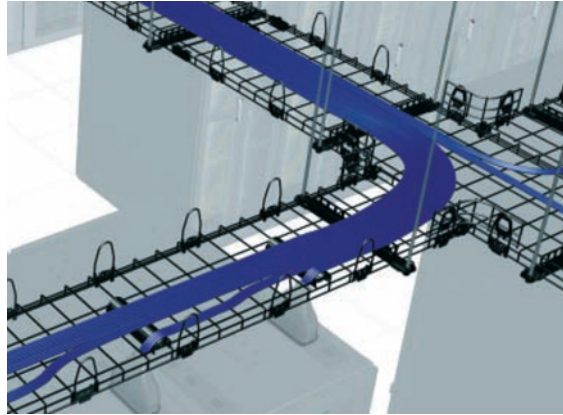

377709

Figure 18 Bend Radius Control Accessory—Waterfall Bend Radius



377800

Figure 19 Bend Radius Control Accessory—Intersection Bend Radius



377801

Another common pathway choice is J-hooks. Panduit J-hooks are designed with a radius to accommodate cables routed down (Figure 20). Flat J-hooks have a sharp edge that can snag cables during installation and, more importantly, damage the fiber cable and lead to signal loss. Using bridle rings can lead to the same issue. Bridle rings and flat J-hooks are not recommended for fiber optic cabling.

Figure 20 J-Hook Showing Bend Radius Control



Figure 21 FiberRunner® Cable Routing System Installation



An additional option for protecting fiber optic cabling is to run it in a dedicated pathway such as the Panduit FiberRunner Cable Routing System. The FiberRunner Cable Routing System is an enclosed pathway with bend radius control features. It also has transitions to equipment shown in [Figure 21](#) and has various mounting capabilities for the ceiling, wall, and cabinet/rack.

When routed in control panels, fiber optic cabling must be carefully laid in duct or protective tubing to avoid snags and kinks while maintaining proper bend radius. Adhesive backed mounting clips can hold fiber optic cabling in place outside of ducts along the panel wall or top ([Figure 22](#)).



Figure 22 Adhesive Backed Mounting Clips for Fiber

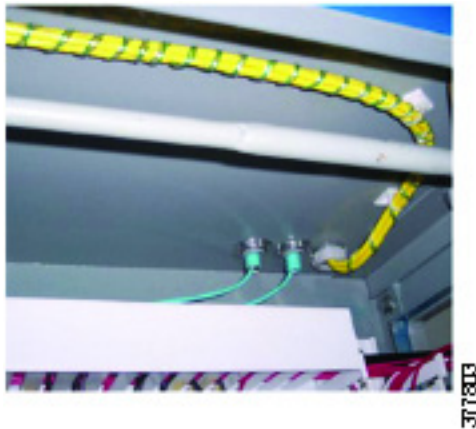

Figure 23 Fiber Patching in a Control Panel



Table 5 summarizes different pathway types and their use with unprotected optical fiber. Optical fiber types are also available that have a metal- (aluminum or steel) or polymer-based flexible armoring protecting the fibers. Such fibers would be suited to pathway types that do not offer continuous or closely spaced points of support.

Table 5 Pathway Comparison

Pathways	Conduit	Duct/Raceways	Grid Type Pathway	Ladder Rack	J-Hooks
Support Given	Continuous	Continuous	Point support, approx. every 3 inches	Point support, approx. every 12 inches	Point support, typically every 4 to 5 feet
Relative Cost	\$\$	\$\$\$	\$\$\$	\$\$	\$
Installed Cost	\$\$\$	\$\$	\$\$	\$\$	\$
Installation Technique	Pull cable and field terminate	Lay cable	Lay cable, manage with hook & loop	Lay cable, manage with hook & loop	Lay cable

Table 5 Pathway Comparison

Pathways	Conduit	Duct/Raceways	Grid Type Pathway	Ladder Rack	J-Hooks
Ease of Adding More Cables	Good (but eventually reaches fill capacity)	Better (requires removal of top cover)	Best	Best	Best
Suitability for Unprotected Installations	Yes	Yes	Yes	No (some installations use duct for protection)	No
Level of Protection Given to Cabling	****	***	**	**	*

## Patching

The best practice for patching is to land fiber cable into an enclosure or box following a structured cabling approach. When fiber is terminated, several inches of the glass strand are exposed which are very fragile and need the enclosure or box to help protect the fiber from damage. Terminating directly to a connector without protection or support can lead to failures. For rack and cabinet installations, a Panduit 19-inch style fiber cassette enclosure is a suitable choice. When installing fiber into a control panel, components such as the DIN Patch Panel or Mini-Com<sup>®</sup> Surface Mount Box (Figure 23) provide patching. Another advantage of structured cabling is the ability to build in spares ready to accommodate growth or to rapidly recover from link failure.

## Bundling Fiber Optic Cable

The best practice for bundling numerous standard jacket fiber cables is to use a hook & loop cable tie (Figure 24). This type of cable tie cannot be over-tightened on the bundle, which can lead to cable damage. The environment of the installation is an important consideration when selecting a hook & loop cable tie. In more caustic environments, an elastomeric tie is a better choice. Elastomeric ties stretch to help prevent over tension, while guarding against weather, oil, salts, etc. Nylon cable ties can potentially damage the cable and are not recommended for standard jacket fiber cable. Nylon ties are only appropriate for armored or DCF fiber optic cabling.

Figure 24 Hook & Loop and Elastomeric Ties for Bundling Fiber



Figure 25 Elastomeric Ties for Bundling Fiber



Figure 26 Fiber Patch Cord Labeling with Sleeve

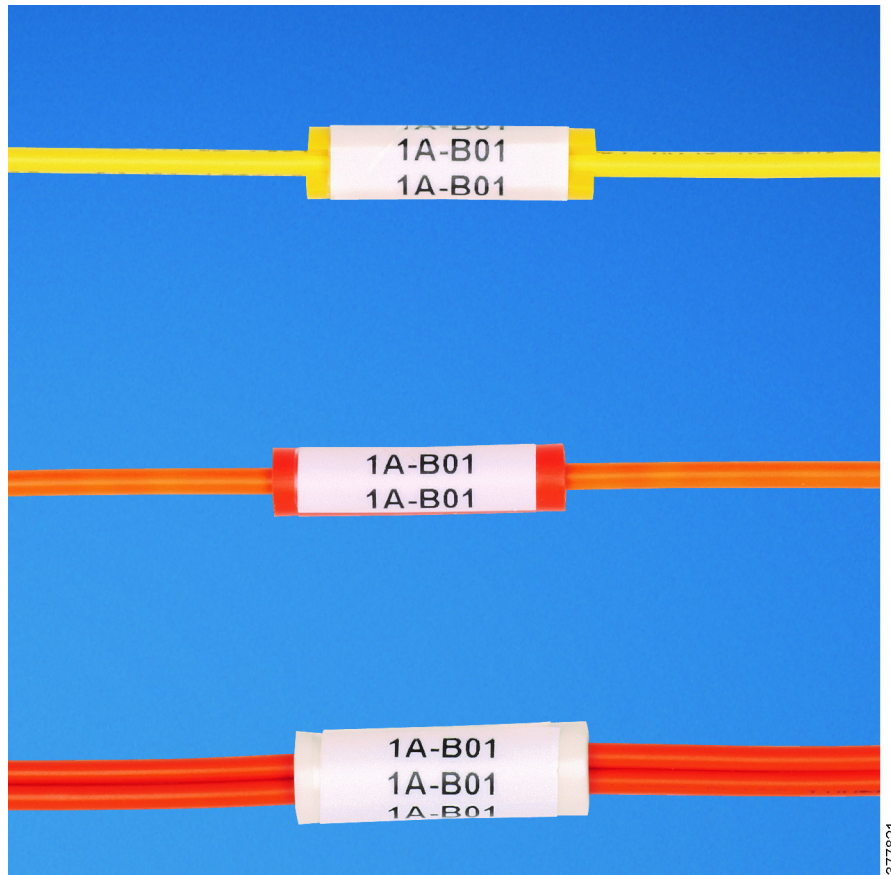

## Fiber Optic Cable Identification

Cable identification facilitates MACs and speeds physical infrastructure management and troubleshooting. Fiber optic cabling identification techniques include labeling and color coding. Labeling should be applied to enclosures, ports, patch cords, horizontal cables, etc. While some individuals consider comprehensive labeling an excessive cost, it pays dividends in effective management and troubleshooting of the physical infrastructure and also greatly shortens outages.

Since some fiber cable types have small diameters, applying labels can be a challenge. To make the label readable a sleeve can be applied, which increases the diameter (Figure 26). The identifying text on all labels should follow TIA-606B standards. For clarity, there is usually a breakdown from the enclosure/rack, rack unit (RU), port, etc. that is consistent throughout the facility. For example, CP1.PP1.02 could signify control panel 1, patch panel 1, and port 2 and can identify VLANs, manufacturing process, location, network traffic type, etc. Color coding can identify VLANs, manufacturing process, location, network traffic type, etc. Color coding can be achieved with labels, hook & loop cable ties, and color bands. Although fiber cable is color coded by cable type, additional color coding can be performed for clarity using the methods described above.

## Pre-Configured and Integrated Products with Fiber Cable Management

Panduit pre-configured and integrated products such as the Physical Network Zone System (PNZS), Industrial Distribution Frame (IDF), and Industrial Data Center (IDC) include fiber cable management features that follow fiber optic cabling best practices. The PNZS includes a strain relief bar to secure the fiber

optic cabling, slack spool, and surface mount box ready to deploy fiber optic cabling. The IDF has corrugated loom tubing to route fiber and a fiber enclosure for patching and protection. The Pre-Configured IDC also has a fiber enclosure.

## Media Selection

This section describes:

- [Cell/Area Zone Fiber Optic Cabling Types](#)
- [Industrial Distribution Frame Fiber Optic Cabling Types and Products](#)
- [Level 3 Site Operations Fiber Optic Cabling Types](#)

### Cell/Area Zone Fiber Optic Cabling Types

This section focuses on the physical infrastructure and fiber strategy most commonly used in the Cell/Area Zone of a CPwE architecture. The Industrial Automation and Control System (IACS) network within the Cell/Area Zone is a major building block of the CPwE architecture. This is the network that connects sensors, actuators, drives, controllers, and any other IACS devices that need to communicate in real-time I/O communication. The Cell/Area Zone network must be designed to meet the performance requirements of the IACS it supports, namely latency and jitter. This section focuses on the physical infrastructure requirements and fiber optic cabling strategy for this portion of the industrial network. It describes the CPwE Cell/Area Zone and discusses key areas of the plant-wide network and the CPwE Industrial Zone. [Figure 27](#) shows the CPwE Logical Framework mapped to a representative physical plant floor layout.

Figure 27 CPwE Logical Framework Mapped to Physical Plant Floor Layout

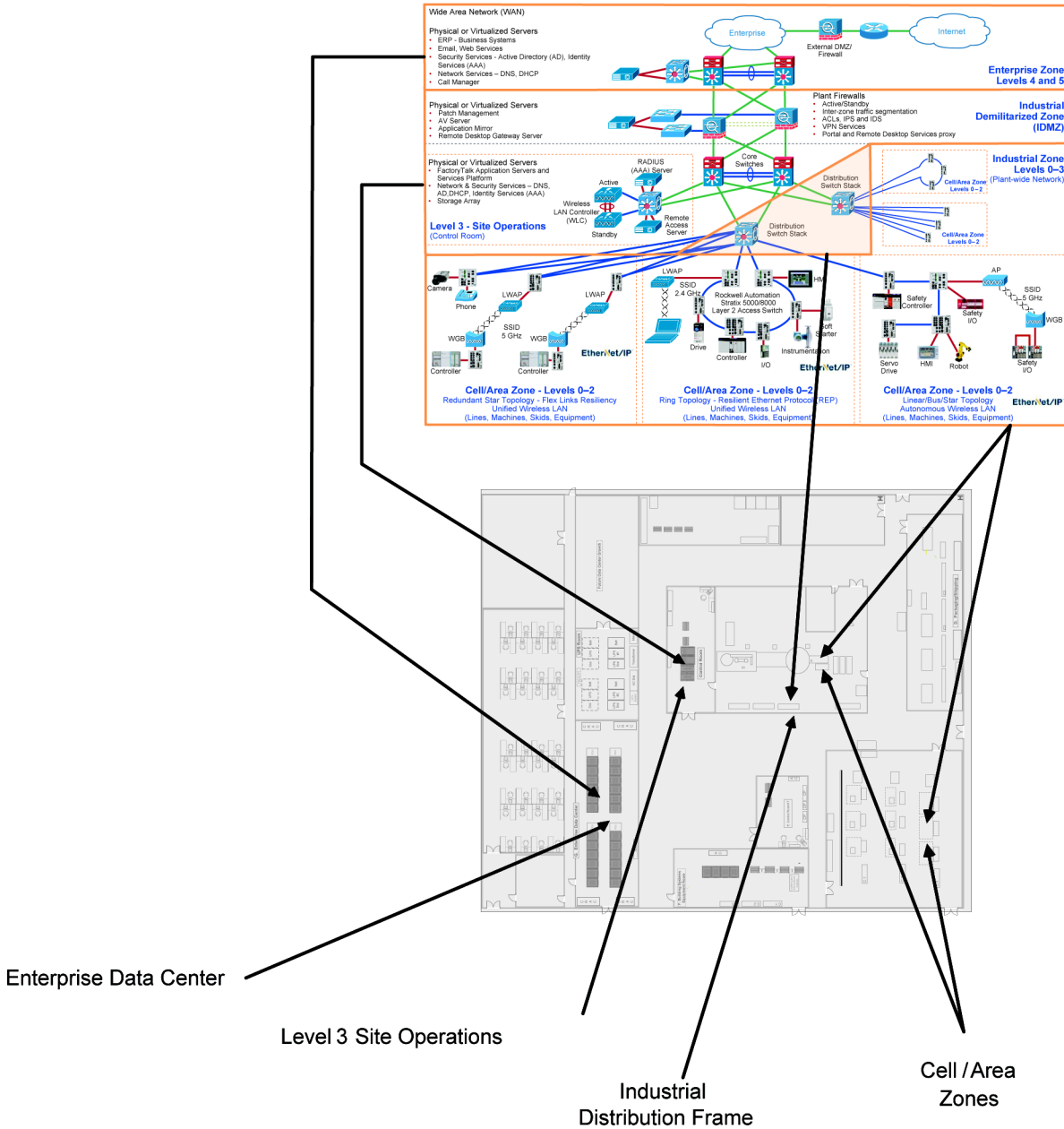

377806

### Hardened Bulkhead Patch Cord

Connecting control panels with fiber using a hardened bulkhead patch cord with an LC connector to a bulkhead LC adapter provides the necessary protection to help achieve reliable communications in a harsh environment. From the LC bulkhead adapter, a patch cord is connected to the device transceiver to complete the channel. An LC connector can be installed into environmentally protective housings. The housings are available in a variety of styles, which the IEC 61076-3-106 standard can be used to identify. In particular, ODVA, Inc., which administers EtherNet/IP, has chosen the Variant 1 housing for industrial protection. The hardened bulkhead patch cord is widely available, is applicable to multiple fiber media types such as OMx

graded index fiber and OS2, and is generally application-agnostic. Figure 28 shows the industrial LC connector system (with the bulkhead and connector plug), which includes the following features:

- IP67-rated to provide adequate environmental protection
- LC duplex connection to enable use of both singlemode and multimode fibers
- Bayonet-style mechanical lock to help maintain mechanical stability connection
- Dual mounting bulkhead design
- ODVA, Inc. compliant as plug-to-plug on cable

Figure 28 LC Bulkhead Connector System



The ODVA, Inc. approved connector system, the industrial LC, is intended for bulkhead applications where dust and water ingress are a concern. It is used in panel-to-panel EtherNet/IP links using fiber optic cabling where special environmental requirements are stated (e.g., an IP67 rating).

This connector system conforms to requirements stated in ODVA, Inc. specifications and addresses the more severe categories of MICE, typically M3, I3, C3, and E3 (which describes a harsh environment industrial space).

The industrial LC bulkhead connector system consists of two main parts, the bulkhead LC adapter and the LC connector patch cord. The bulkhead LC adapter consists of a bulkhead with a seal to hold the LC adapter, which is attached by a nut. Dust caps help prevent contamination of the adapter when not in use or prior to installation. Dust caps for the adapter are usually small plastic inserts that are located into the adapter ferrule and are removed for normal data communications use. The LC connector patch cord consists of a flex tail for strain relief and a plug holder to secure the LC connector. Dust caps are also included to help prevent contamination of the connector when not in use or prior to installation.

## Industrial Distribution Frame Fiber Optic Cabling Types and Products

This section describes the fiber products most commonly used in the Industrial Distribution Frame (IDF) of a CPwE architecture. The Industrial Zone (Levels 0-3) ties together the Cell/Area Zone (Levels 0-2) and Level 3 Site Operations in the CPwE architecture. This connection is accomplished logically and physically through distribution switches connected with optical fiber cabling. Due to the port density and features required for the functions performed by the distribution switch(es), often 19-inch rack mount gear is used in this application. Sometimes the switch may be an enterprise-grade device. Therefore, special care is required to protect the switches and have them function reliably in industrial environments. The Industrial Distribution Frame shown in Figure 29 is a solution with features to provide appropriate environmental protection while optimizing the cabling, grounding/bonding, and installation of devices.

Figure 29 Industrial Distribution Frame (IDF)

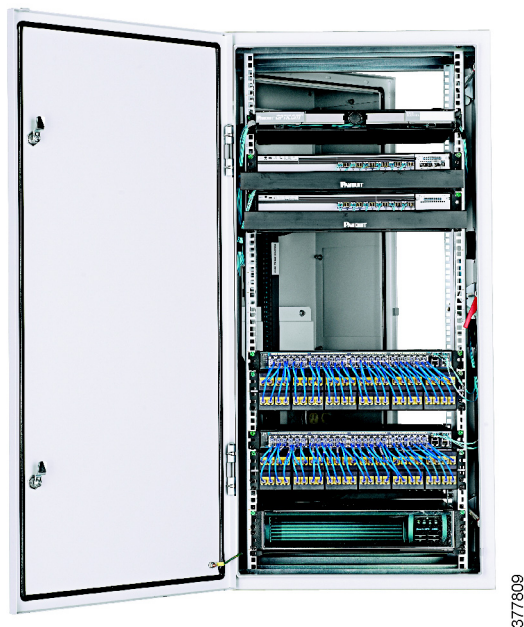

The IDF is a dual-hinged enclosure (i.e., outer door and movable middle section) with RU mounting provisions that accommodate expected network switch depths. The movable middle section provides access to the back of the switches when opened. In addition, it provides access to the cabling entrance and cable management features. Although this type of enclosure has been around many years, it is only recently that it has been used to address numerous challenges ranging from cable management, cooling, MACs, enclosure mounting, etc.

These challenges are overcome by deploying a pre-configured IDF that contains the necessary infrastructure components to help minimize deployment risks for reliability, maintenance, and missed schedules. Although active equipment varies from location to location, the pre-configured IDF can support up to two Cisco Catalyst 3850 switches, a 2 RU high Universal Power Supply (UPS), with up to 3 open RUs.

The pre-configured IDF is designed with fiber cable management best practices which help protect the fiber cable from bend radius issues. Near the top of the enclosure, the cable is transitioned horizontally in a corrugated tube to maintain protection and landing on a fiber enclosure. This is a specially designed fiber enclosure that enables proper bend radius and appropriate slack management to the fiber adapter panel (FAP), handling many strands of exposed fiber cable. The fiber strand is terminated to an LC MiniCom™ Connector that is inserted into the back of a FAP. The fiber enclosure can have 1-3 FAPs with varying adapter density and is secured to the front of the fiber enclosure. The switch uplink port is connected to the front of



the FAP. At the rear of the FAP, the backbone cabling is connected and completes the channel. Patch cords must be carefully routed to the switches, maintaining acceptable bend radii. Labeling the cable is recommended and since the cable diameter is very small, a label sleeve should be applied for the label.

## Industrial Zone Fiber Optic Cabling

Industrial Zone fiber optic cabling encounters many physical extremes in industrial environments, requiring more enhanced protection than cables in enterprise deployments. There are many options to encase the fiber optic cabling. The simplest option is corrugated tubing, which offers very basic and moderate protection such as crush resistance and some bend radius control because the material resists tight bends. More robust protection includes metal clad, dielectric-conduited, and fiber in conduit, which are more suitable choices for industrial and harsh environments.

## Enterprise Fiber Cable in Conduit

In harsh or splashdown environments, fiber optic cabling in conduit that is sealed and constructed of stainless steel may be necessary for added protection. Conduit has the highest crush resistance when compared to other cable protection options. Deploying fiber in conduit is not the same as deploying copper cables, especially power wires, because bend radius is not a factor for non-network cables. When transitioning cable 90 degrees, the conduit should be bent with the proper bend radius. The use of elbows and T connections is not advised for fiber or copper network cabling.

The cabling routed through the conduit can be enterprise grade because the conduit provides all the necessary protection. When pulling fiber cable in conduit, the pulling tension must be carefully monitored to avoid cable damage due to over-tensioning. Cable routes must include an adequate number of pull boxes to ease installation. It is not advised to mix different types of cabling in the conduit.

## Dielectric Conduited Fiber Armored Cable

The Dielectric Conduited Fiber (DCF) armored cable provides high-density connectivity and is constructed of a rugged plastic exterior conduit that is extruded over a standard tight buffered fiber distribution cable. DCF can be used in indoor applications that normally require armored cable or protection by conduit. The DCF cable is available with OM1, OM2, OM3, and OM4 multimode distribution cable or OS2 singlemode distribution cable routed in the conduit. The exterior may be colored to match the glass grade. For example, an OM3 DCF cable is colored aqua.

DCF cable ([Figure 30](#)) has a crush resistance six times greater than that of an unarmored cable rated at 5.88 N-m (52.4 in-lbs). The all-dielectric properties avoid the grounding and bonding requirements that pertain to the standard metal armored type and are required by code. The elimination of bonding connections simplifies installation and reduces cost. Since DCF is very lightweight and mechanically supports the fiber cable to avoid sagging, it can use easy-to-install, low-cost J-hooks and ladder racks.

Figure 30 Dielectric Conduited Fiber



## Level 3 Site Operations Fiber Optic Cabling Types

This section describes the fiber products most commonly used in the Level 3 Site Operations of a CPwE architecture. The Level 3 Site Operations ties together the Industrial Demilitarized Zone (IDMZ) and Industrial Distribution Frame in the CPwE architecture. These links are accomplished logically and physically through core switches, distribution switches, and firewalls (IDMZ) connected with optical fiber cabling.

### Indoor Distribution Cable

Indoor distribution cable provides high density connectivity and is used for intra-building backbones, routing between telecommunications rooms and cables in riser and plenum environments. Distribution cable is the most popular indoor cable as it is small in size, lightweight, and easy to install. When selecting distribution cabling, it is important to consider the different cable fire ratings to determine which ones are appropriate for your specific installation requirements. The National Electric Code (NEC) designates flame ratings for cables to help prevent the spread of fire and smoke in commercial and residential buildings. Depending on where the cables run in your industrial network, a requirement for a higher flame rating may arise.

## Cable Fire Ratings Reference Guide

Cable fire ratings need to be considered when specifying cabling infrastructure to ensure local building codes are met. The rating reference guide below provides the information needed to determine which rating is appropriate for different installation environments

### Plenum Rated Cable

An Optical Fiber, Nonconductive, Plenum (OFNP) rating signifies cable that has passed stringent burn testing and is suitable for installation into air plenum spaces. OFNP cables have fire resistance and low smoke production characteristics. They can be installed in ducts, plenums, and other spaces used for building airflow. This is the highest fire rating fiber cable and no other cable types can be used as substitutes.

### Plenum Rated Cable

An Optical Fiber, Conductive, Plenum (OFCP) rating differs from OFNP in that the cable contains metallic elements, typically armor, and therefore conducts electricity. All other aspects of this rating are the same as OFNP.

### Riser Rated Cable

An Optical Fiber, Nonconductive, Riser (OFNR) rating is commonly required when cables are run between floors through open vertical shafts. OFNR cables are used in riser areas which are building vertical shafts or runs from one floor to another floor. OFNR cables cannot be installed in plenum areas since they do not have the same required smoke rating as plenum rated cables. OFNP plenum cables can be used as a substitute for OFNR riser cables.

### Riser Rated Cable

An Optical Fiber, Conductive, Riser (OFCR) rating differs from OFNR in that the cable contains metallic elements, such as a layer of armor, and therefore conducts electricity. All other aspects of this rating are the same as OFNR.

### Low Smoke Zero Halogen

A Low Smoke Zero Halogen (LSZH) rating is sometimes referred to as low toxicity cable. When burned, PVC-based cables produce a cloud of toxic smoke containing corrosive compounds such as hydrochloric acid. The LSZH cables do not contain the halogen type compounds that form these toxic substances. Smoke emitted from burning LSZH cables do not produce the toxic halogen-based gases previously mentioned. LSZH ratings are expressed as OFN-LS or OFNR-LS if the cable also meets the requirements of a OFNR rated cable.

## Patch Cords

Patch cords provide flexible connection between the horizontal cabling infrastructure and the desired ports on the switch. These connections should always be made via patching so link testing may be accurately performed and so re-routing at the patch panel is possible in case of a horizontal cabling failure.

## LC Patch Cord

The LC patch cord connects the horizontal cable to the device and is the leading patch cord type in IACS applications for Rockwell Automation and Cisco industrial Ethernet switching (IES) products. For proper deployment, the patch cord must match the horizontal cable grade index. For example, an OM1 horizontal cable is only compatible with an OM1 patch cord. A best practice is to match the jacket color of the horizontal cable to the patch cord. For example, an OM3 aqua jacket must match the horizontal aqua cable. This simple color match greatly streamlines troubleshooting and management as the eye is drawn to the proper color.

## Standard Patch Cord

Standard patch cords with LC connectors are available in various lengths. Patch cord lengths are stocked and sold in increments of feet, such as three feet, four feet, etc. Standard LC patch cords are available in all of the grade index types, multimode OM1 through OM4 as well as singlemode OS2. Standard patch cords are tested and validated to help achieve quality performance in the field. As a general rule, the use of factory patch cords helps increase system performance and reliability by avoiding the potential variability in field-produced patch cords.

## Hybrid Patch Cord

There are cases where legacy fiber is already present in a fiber installation with other connector types such as SC, ST, FC, MT-RJ, etc. Panduit provides patch cords that allow patching to the legacy connector on one end to an LC connection suitable for joining Allen-Bradley SFP LC connections or other LC connections in the system (Figure 31).

Figure 31 Hybrid Patch Cord Options—LC to ST



## Conclusion

Resilient plant-wide network architectures serve a crucial role in helping to maximize overall plant uptime and productivity. The CPwE architecture provides standard network services to the applications, devices, and equipment in modern IACS applications and integrates them into the wider Enterprise Zone via an IDMZ. Successful deployments of CPwE architecture depend on a robust physical network infrastructure design that

addresses environmental, performance, and security challenges, drawing upon proven best practices from OT and IT disciplines. Fiber optic cabling is a key portion of the infrastructure in a CPwE architecture. This document provides guidance for deploying optimized fiber solutions based on several factors:

- First, define the correct mode type of singlemode or multimode and, if multimode fiber is required, the correct grade of multimode fiber.
- Second, determine the number of fiber optic strands needed in each cable run.
- Finally, select the appropriate cable construction for the environment.

This application guide can be viewed as an extension to the Cisco and Rockwell Automation CPwE *Deploying a Resilient Converged Plantwide Ethernet Architecture Design and Implementation Guide* ([http://literature.rockwellautomation.com/idc/groups/literature/documents/td/enet-td010\\_-en-p.pdf](http://literature.rockwellautomation.com/idc/groups/literature/documents/td/enet-td010_-en-p.pdf)).

## Fiber Optic Cable Handling and Safety

When terminating optical fibers, there are specific precautions that must be taken to help maintain worker safety and to avoid damage to the cabling. For example, workers should always wear proper eye protection and work in a clean, spacious environment. Other precautions include:

- **Eye Safety**—It is strongly recommended that safety glasses be worn when handling bare optical fiber. The bare fiber is very sharp and can easily damage the eye.
- **Isopropyl Alcohol**—Isopropyl alcohol is flammable. Contact with the alcohol can cause irritation to the eyes. In case of contact with the eyes, flush with water for at least 15 minutes. Always use isopropyl alcohol with proper levels of ventilation. In case of ingestion, consult a physician immediately.
- **Disposal of Bare Fibers**—Pick up and discard all pieces of bare fiber with sticky tabs. Do not allow cut pieces of fiber to stick to clothing or drop in the work area where they are hard to see and can cause injury.
- **Laser Light**—According to Class 1M laser product of the IEC 60825-1 standard, do not directly view laser output with optical instruments. Viewing the laser output with certain optical instruments (e.g., eye loupes, magnifiers, and microscopes) within a distance of 100mm may pose an eye hazard.

Use of controls or adjustments or performance of procedures other than those specified herein may result in hazardous radiation exposure.

- Never point the laser into the eyes of others.
- Do not stare directly at the laser beam.
- Do not set up the tool to work at eye level or operate the tool on a reflective surface as the laser could be projected into your eyes or the eyes of others.

Always turn the laser off when it is not in use or is left unattended for a period of time. Remove the batteries when storing them for an extended period of time to avoid damage to the tool if the batteries deteriorate.

For more information on safely handling fiber optic cabling, refer to the Fiber Optic Association's *User's Guide to Fiber Optic System Design and Installation* (<http://www.thefoa.org/tech/ref/safety/safe.html>).

Panduit Corp. is a world-class provider of engineered, flexible, end-to-end electrical and network connectivity infrastructure solutions that provides businesses with the ability to keep pace with a connected world. Our robust partner ecosystem, global staff, and unmatched service and support make Panduit a valuable and trusted partner.

#### www.panduit.com

US and Canada: Panduit Corp. World Headquarters 18900 Panduit Drive Tinley Park, IL 60487 iai@panduit.com Tel. 708.532.1800	Asia Pacific: One Temasek Avenue #09-01 Millenia Tower 039192 Singapore Tel. 65 6305 7555	Europe/Middle East/Africa: Panduit Corp. West World Westgate London W5 1XP Q United Kingdom Tel. +44 (0) 20 8601 7219	Latin America: Panduit Corp. Periférico Pte Manuel Gómez Morin #7225 - A Guadalajara Jalisco 45010 MEXICO Tel. (33) 3777 6000
---	---	--	---

Panduit, OptiCam, Wyr-Grid, FiberRunner, and Mini-Com are trademarks of the Panduit Corporation.

Cisco is the worldwide leader in networking that transforms how people connect, communicate and collaborate. Information about Cisco can be found at [www.cisco.com](http://www.cisco.com). For ongoing news, please go to <http://newsroom.cisco.com>. Cisco equipment in Europe is supplied by Cisco Systems International BV, a wholly owned subsidiary of Cisco Systems, Inc.

#### www.cisco.com

Americas Headquarters Cisco Systems, Inc. San Jose, CA	Asia Pacific Headquarters Cisco Systems (USA) Pte. Ltd. Singapore	Europe Headquarters Cisco Systems International BV Amsterdam, The Netherlands
--	---	---

Cisco has more than 200 offices worldwide. Addresses, phone numbers, and fax numbers are listed on the Cisco Website at [www.cisco.com/go/offices](http://www.cisco.com/go/offices).

Cisco and the Cisco logo are trademarks or registered trademarks of Cisco and/or its affiliates in the U.S. and other countries. To view a list of Cisco trademarks, go to this URL: [www.cisco.com/go/trademarks](http://www.cisco.com/go/trademarks). Third-party trademarks mentioned are the property of their respective owners. The use of the word partner does not imply a partnership relationship between Cisco and any other company. (1110R)

Rockwell Automation is a leading provider of power, control and information solutions that enable customers to be more productive and the world more sustainable. In support of smart manufacturing concepts, Rockwell Automation helps customers maximize value and prepare for their future by building a Connected Enterprise.

#### www.rockwellautomation.com

Americas: Rockwell Automation 1201 South Second Street Milwaukee, WI 53204-2496 USA Tel: (1) 414.382.2000 Fax: (1) 414.382.4444	Asia Pacific: Rockwell Automation Level 14, Core F, Cyberport 3 100 Cyberport Road, Hong Kong Tel: (852) 2887 4788 Fax: (852) 2508 1846	Europe/Middle East/Africa: Rockwell Automation NV, Pegasus Park, De Kleetlaan 12a 1831 Diegem, Belgium Tel: (32) 2 663 0600 Fax: (32) 2 663 0640
--	--	---

Allen-Bradley, Rockwell Automation and Rockwell Software are trademarks of Rockwell Automation, Inc. Trademarks not belonging to Rockwell Automation are property of their respective companies.

EtherNet/IP is a trademark of ODVA, Inc.