

THIS COPY IS PROVIDED ON A RESTRICTED BASIS AND IS NOT TO BE USED IN ANY WAY DETRIMENTAL TO THE INTERESTS OF PANDUIT CORP.

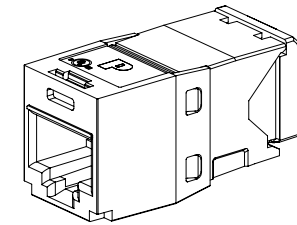
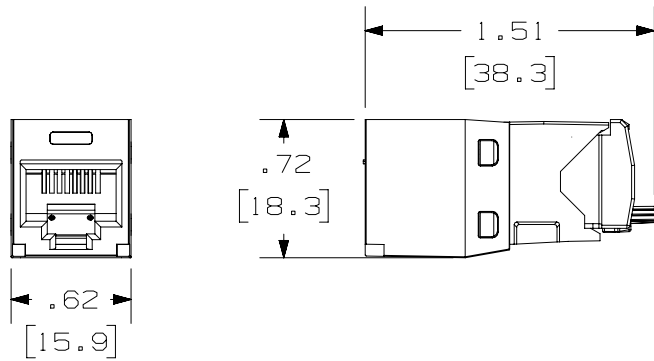
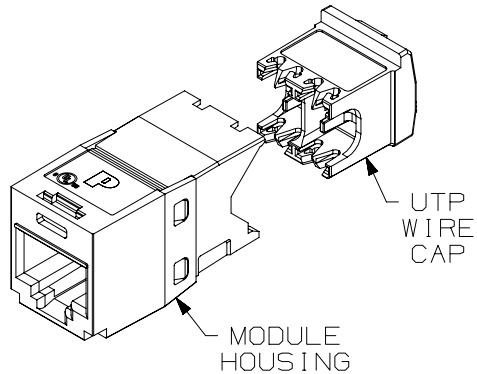

ACTUAL SIZE

NOTES:

1. VISIT OUR ON-LINE CATALOG AT WWW.PANDUIT.COM FOR A LIST OF CURRENT PARTS APPLICABLE FOR USE WITH THIS PRODUCT.
2. WHITE COLOR WIRE CAP ASSEMBLY DESIGNATES TIA CATEGORY 6 (ISO 11801 CLASS E) PERFORMANCE. RED COLOR WIRE CAP ASSEMBLY DESIGNATES TIA CATEGORY 5e (ISO 11801 CLASS D) PERFORMANCE.
3. COLOR OF JACK MODULE IS INDICATED BY \*\* IN THE PART NUMBER (EXAMPLE: CJ\*\*8BTGBU FOR BLUE JACK), SEE WWW.PANDUIT.COM FOR AVAILABLE COLOR CODES.
4. PART NUMBERS ON AVAILABLE PACKAGE TYPES ARE SHOWN IN TABLE 1
5. TERMINATION TOOL TO BE USED IS EGJT-1. SOME PACKAGE TYPES INCLUDE A TERMINATION TOOL, SEE TABLE 1 FOR DETAILS
6. ALL MINI-COM™ CATEGORY 5e/6, 8 POSITION, 8 WIRE CONNECTOR MODULES ARE UNIVERSAL IN DESIGN. THEY ACCEPT ACCEPT SIX AND EIGHT POSITION MODULAR PLUGS WITHOUT DAMAGE.
7. TERMINATES 22-26AWG SOLID OR STRANDED UTP CABLE STRAIGHT HORIZONTALLY.
8. SEE INSTALLATION INSTRUCTION FOR PROPER TERMINATION METHOD.
9. WIRE CAP LABEL WHICH IS PART OF THE WIRE CAP ASSEMBLY IS CODED FOR T568A AND T568B WIRING SCHEMES.
10. PART INCLUDES:
  - 1- MODULE HOUSING: POLYCARBONATE W/ UL94V-0 FLAME RATING.
  - 1- WIRE CAP ASSEMBLY: POLYCARBONATE W/ UL94V-0 FLAME RATING.
11. WEIGHT: 1.53 LBS/ 100 PCS (695 g/ 100 PCS).
12. DIMENSIONS IN [ ] ARE METRIC.
13. ALL MATERIALS AND COMPONENTS USED MEET THE LATEST RoHS REQUIREMENTS.

TABLE 1: PACKAGE TYPE AND TERMINATION TOOL

PART NUMBER	PACKAGED QUANTITY	TERMINATION TOOL: EGJT-1
CJ**88TG**	INDIVIDUALLY PACKAGED, 50 PER CARTON	NOT INCLUDED
CJ**88TG**-24	BULK PACKAGED, 24 PER BAG	NOT INCLUDED
CJ**688TG**-C	BULK PACKAGED, 100 PER CARTON	INCLUDED (1 PER CARTON)

PART NUMBER		SEE TABLE 1	
TITLE			
MINI-COM CATEGORY 5e/6 JACK MODULE WITH		STRAIGHT WIRE CAP ASSEMBLY	
CUSTOMER DRAWING			
ITEM REVISION NAME		00075SAU/00	
DATASET FILE NAME		00075SAU_DC02/00B	
		THIRD ANGLE PROJECTION	
MATERIAL		SEE NOTE 10	
DRAWING NUMBER		00075SAU-02	
DRAWN BY	DATE	CHK	SCALE
BJN	11-11-19	ROJC	FULL
SHEET 1 OF 1		A	

REV	DATE	BY	CHK	APR	DESCRIPTION	ECN
00B	9-7-23	TWV	ROJC	JEFK	UPDATED TABLE 1	M09000UD
00A	11-11-19	BJN	ROJC	TMBA	RELEASED TO PRODUCTION	M09000KV