

THIS COPY IS PROVIDED ON A RESTRICTED BASIS AND IS NOT TO BE USED IN ANY WAY DETRIMENTAL TO THE INTERESTS OF PANDUIT CORP.

NOTES:

1. VISIT OUR ON-LINE CATALOG AT WWW.PANDUIT.COM FOR A LIST OF CURRENT PARTS APPLICABLE FOR USE WITH THIS PRODUCT.
2. BLUE COLOR WIRE CAP ASSEMBLY DESIGNATES TIA CATEGORY 6A (ISO 11801 CLASS EA) PERFORMANCE.
3. TO DESIGNATE A JACK MODULE COLOR, ADD A TWO LETTER COLOR NUMBER SUFFIX. SEE CURRENT CATALOG FOR AVAILABLE PART NUMBER SUFFIXES TO INDICATE COLOR AND/OR PACKAGE QUANTITY.
4. ALL TX6A™ 10GIG™ CATEGORY 6A, 8 POSITION, 8 WIRE CONNECTOR MODULES ARE UNIVERSAL IN DESIGN. THEY ACCEPT ACCEPT SIX AND EIGHT POSITION MODULAR PLUGS WITHOUT DAMAGE.
5. TERMINATES 22-26AWG SOLID OR STRANDED UTP CABLE
6. SEE INSTALLATION INSTRUCTION FOR PROPER TERMINATION METHOD.
7. WIRE CAP LABEL WHICH IS PART OF THE WIRE CAP ASSEMBLY IS CODED FOR T568A AND T568B WIRING SCHEME.
8. PART INCLUDES:
 - 1- MODULE HOUSING: POLYCARBONATE W/ UL94V-0 FLAME RATING.
 - 1- WIRE CAP ASSEMBLY: POLYCARBONATE W/ UL94V-0 FLAME RATING.
9. WEIGHT: 1.53 LBS/ 100 PCS (695 g/ 100 PCS).
10. DIMENSIONS IN [] ARE METRIC.
11. ALL MATERIALS AND COMPONENTS USED MEET THE MATERIAL RESTRICTIONS OF RoHs (EUROPEAN DIRECTIVE 2011/65/EU ON THE RESTRICTION OF HAZARDOUS SUBSTANCES) AS PROPOSED BY THE RoHs TECHNICAL ADAPTATION COMMITTEE.

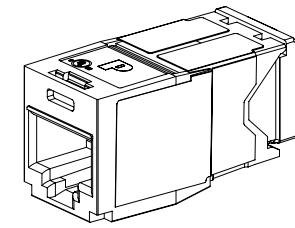
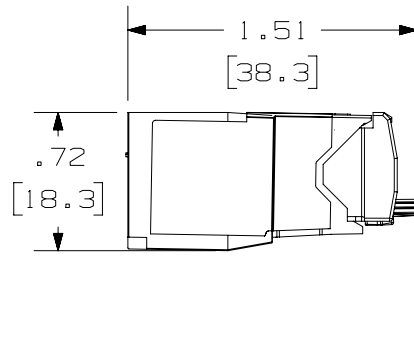
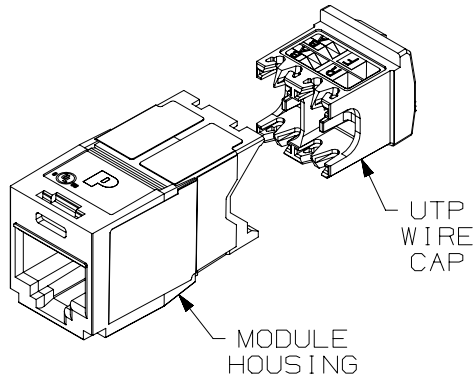

ACTUAL SIZE

TABLE 1: PACKAGE TYPE AND TERMINATION TOOL

PART NUMBER	PACKAGED QUANTITY	TERMINATION TOOL: EGJT-1
CJ6X88TG**	INDIVIDUAL PACKAGED, 50 PER CARTON	NOT INCLUDED
CJ6X88TG**-24	BULK PACKAGED, 24 PER BAG	NOT INCLUDED
CJ6X88TG**-C	BULK PACKAGED, 100 PER CARTON	INCLUDED (1 PER CARTON)

PART NUMBER		CJ6X88TG**		
TITLE		TX6A™ 10GIG™ CATEGORY 6A JACK MODULE WITH STRAIGHT WIRE CAP ASSEMBLY		
ITEM REVISION NAME		CUSTOMER DRAWING		
DATASET FILE NAME		00075SAU/00		
MATERIAL		00075SAU-DC01/00B		
DRAWING NUMBER		PANDUIT		
THIRD ANGLE PROJECTION		00075SAU-01		
SEE NOTE 8		SHEET 1 OF 1		
DRAWN BY	DATE	CHK	SCALE	SIZE
BJN	11-11-19	ROJC	FULL	A

REV	DATE	BY	CHK	APR	DESCRIPTION	ECN
00B	9-7-23	TWV	ROJC	JEFK	UPDATED TABLE 1	M09000UD
00A	11-11-19	BJN	ROJC	TMBA	RELEASED TO PRODUCTION	M09000KV